

CAREC Road Safety Engineering Manual 4

PEDESTRIAN SAFETY

FEBRUARY 2021

CAREC Road Safety Engineering Manual 4

PEDESTRIAN SAFETY

FEBRUARY 2021





Creative Commons Attribution 3.0 IGO license (CC BY 3.0 IGO)

© 2021 Asian Development Bank
6 ADB Avenue, Mandaluyong City, 1550 Metro Manila, Philippines
Tel +63 2 8632 4444; Fax +63 2 8636 2444
www.adb.org

Some rights reserved. Published in 2021.

ISBN 978-92-9262-126-1 (print); 978-92-9262-127-8 (electronic); 978-92-9262-128-5 (ebook)
Publication Stock No. TIM210073-2
DOI: <http://dx.doi.org/10.22617/TIM210073-2>

The views expressed in this publication are those of the authors and do not necessarily reflect the views and policies of the Asian Development Bank (ADB) or its Board of Governors or the governments they represent.

ADB does not guarantee the accuracy of the data included in this publication and accepts no responsibility for any consequence of their use. The mention of specific companies or products of manufacturers does not imply that they are endorsed or recommended by ADB in preference to others of a similar nature that are not mentioned.

By making any designation of or reference to a particular territory or geographic area, or by using the term “country” in this document, ADB does not intend to make any judgments as to the legal or other status of any territory or area.

This work is available under the Creative Commons Attribution 3.0 IGO license (CC BY 3.0 IGO) <https://creativecommons.org/licenses/by/3.0/igo/>. By using the content of this publication, you agree to be bound by the terms of this license. For attribution, translations, adaptations, and permissions, please read the provisions and terms of use at <https://www.adb.org/terms-use#openaccess>.

This CC license does not apply to non-ADB copyright materials in this publication. If the material is attributed to another source, please contact the copyright owner or publisher of that source for permission to reproduce it. ADB cannot be held liable for any claims that arise as a result of your use of the material.

Please contact pubsmarketing@adb.org if you have questions or comments with respect to content, or if you wish to obtain copyright permission for your intended use that does not fall within these terms, or for permission to use the ADB logo.

Corrigenda to ADB publications may be found at <http://www.adb.org/publications/corrigenda>.

Notes:

In this publication, “\$” refers to US dollars.

Photo credits: All photos are from Phillip Jordan (ADB road safety engineering consultant) except photos from other sources as indicated in the captions.

Most of the photographs in this manual were taken in CAREC countries, but a few are from other countries, including some where driving takes place on the left side of the road. Some of these photographs were flipped horizontally to help the reader understand the message better; others showing road signs that do not suit being flipped were kept in their original state. Those few photos appear with a note stating “left-side driving,” for clarity.

Contents

Tables and Figures	v
Abbreviations	vi
Purpose of This Manual	vii
I. Pedestrians—The Forgotten Road Users	1
A. Pedestrians	1
B. Who walks, where, and why?	3
C. Why some people do not walk	4
II. Planning for Pedestrian Safety	7
A. Engineers have an important role in pedestrian safety	7
B. Adopting the Safe System to make roads more pedestrian-friendly	7
C. Planning for pedestrians	8
D. Ensuring good enforcement	9
III. Special Groups of Pedestrians	11
A. Children	12
B. Senior citizens	13
C. Intoxicated pedestrians	15
D. Disabled pedestrians	17
IV. Segregation, Separation, and Integration	24
A. Considering the options	24
B. Segregation	25
C. Separation	26
D. Integration	28
V. Pedestrian Facilities	30
A. Assisting pedestrians in crossing a road safely	30
B. Spatial (distance) separation facilities	33
C. Active and passive temporal (time) separation pedestrian facilities	35
D. Active pedestrian crossing facilities	37
E. Passive time separation crossings	49
F. Helping pedestrians walk safely along rural roads	56
VI. Civil Works to Assist Pedestrians	59
A. Footpaths	59
B. Removal of tripping and snagging hazards	60
C. Curb ramps (smooth crossovers)	62
D. Tactile ground surface indicators	63
E. Pedestrian refuges	66
F. Curb extensions	68
G. Medians	70
H. Bus stops	72
I. Pedestrian fencing	73

J. Threshold treatments	75
K. Streetlighting	76
L. Bridging over drains	77
M. Improved skid resistance	78
N. Pedestrians at railway crossings	78
VII. Traffic Calming	80
A. Traffic-calming devices	81
B. Advantages of traffic calming	87
C. Disadvantages of traffic calming	87
D. Shared zones	87
VIII. Case Studies	89
A. Case study 1	89
B. Case study 2	92
C. Case study 3	95
D. Case study 4	98
E. Case study 5	101
F. Case study 6	103
G. Case study 7	106
IX. Next Steps	109
A. Government policies are paramount	109
B. Road authorities lead national actions	109
C. Engineers manage many good programs for pedestrian safety	109
D. Engineers can do many good individual things...	110
E. ...But engineers need to be cautious with other things	110
F. Walking is good for everyone	110
Appendix 1: Advanced Signal Options to Assist Pedestrians	112
Appendix 2: Crash Reduction Factors	114
Appendix 3: The Stockholm Declaration	116
Glossary of Terms	118
References	121

Tables and Figures

TABLES

1	Design Considerations for Child Pedestrians	13
2	Design Considerations for Senior Pedestrians	15
3	Design Considerations for Intoxicated Pedestrians	16
4	Design Considerations for Mobility-Impaired Pedestrians	18
5	Design Considerations for Wheeled Pedestrians	20
6	Design Considerations for Sensory-Impaired Pedestrians	23
7	Appropriateness of Pedestrian Facilities, by Road Classification	31
8	Design Considerations for Crossings	32
9	Width Requirements for Pedestrian Paths	60

FIGURES

1	A Representation of Mobility vs. Land Access	8
2	Hierarchy for Considering Solutions	8
3	Probability of Fatal Injury for a Pedestrian when Struck by a Motor Vehicle	9
4	Required Path Width for Users with Mobility Impairment	18
5	Wheelchair-Turning Envelope	19
6	Path Widths for Various Wheeled Users	21
7	Simple Two-Phase Signal Diagram Showing Pedestrians (Dashed Lines) Walking in Parallel with Traffic	38
8	Fully Controlled Left Turn	38
9	Pedestrian Movement Intervals	40
10	Layout for a Set of Midblock Pedestrian Signals across a Divided Multilane Road	43
11	Signal Phasing for a PELICAN Crossing	45
12	Push-Button Location and Orientation	48
13	A Typical Pedestrian Push-Button Arrangement	48
14	Required Footpath Width	59
15	Example of a Curb Ramp Design	63
16	Layout for a Curb Extension with a Curb Ramp and TGSIs	68
17	Curb Extensions Used in Conjunction with a Pedestrian (Zebra) Crossing	70
18	The Involvement of Speed in Pedestrian Collisions	80
19	Case Study 3	97
20	Case Study 4	100
21	Case Study 5	102
22	Case Study 6	105

Abbreviations



ADB	-	Asian Development Bank
BAC	-	blood alcohol concentration
CAREC	-	Central Asia Regional Economic Cooperation (Program)
CI	-	CAREC Institute
CRF	-	crash reduction factor
iRAP	-	international road assessment program
km	-	kilometer
km/h	-	kilometers per hour
m	-	meter
mm	-	millimeter
m/sec	-	meters per second
PELICAN	-	pedestrian light-controlled (crossing)
POS	-	pedestrian-operated signal (crossing)
PUFFIN	-	pedestrian user-friendly intelligent (crossing)
RTOR	-	right turn on red
TGSI	-	tactile ground surface indicator
vpd	-	vehicles per day

Purpose of This Manual



The Central Asia Regional Economic Cooperation (CAREC) countries committed themselves to road safety at the 14th CAREC Program Ministerial Conference in Mongolia in September 2015. The Regional Road Safety Strategy for CAREC Countries, 2017–2030, was endorsed by ministers from all the CAREC countries during the 15th Ministerial Conference in Pakistan in October 2016. The strategy supports and encourages governments and road authorities to plan, design, construct, and maintain roads, with road safety as a key and specific objective.

This Pedestrian Safety manual is a practical point of reference for the provision of safer pedestrian facilities in CAREC countries. It is aimed at expanding understanding of how best to assist pedestrians in the CAREC region. It outlines proven facilities that have been shown to assist pedestrians, with full information about these facilities for those responsible for providing them (practitioners) as well as for those who manage the road network (policy makers). The manual urges road authorities across the CAREC region to embrace the Safe System (see Chapter 2.B) and, in so doing, to give attention and resources to the provision of safe pedestrian facilities.

Pedestrians make up the largest group of road user fatalities in several CAREC countries, including Azerbaijan (42% of all reported road fatalities), the Kyrgyz Republic (40%), Tajikistan (40%), Mongolia (29%), and Georgia (27%). Pedestrian trauma is a major part of national road trauma costs. Wise investment in pedestrian facilities will save lives, prevent injuries, and return economic benefits to CAREC countries.

This manual is intended for highway and road safety engineers, project managers, planners, municipal engineers, traffic police, consultants, and representatives of design institutes and road agencies. It focuses on the physical road infrastructure that can help pedestrians safely cross, and walk along, roads. The following are discussed in this manual:

- a strategic approach to managing pedestrian safety, in line with Safe System principles;
- the three main elements of a pedestrian safety strategy;
- the four groups of pedestrians most at risk, and ways to keep them safe;
- pedestrian facilities that are practical, efficient, and useful;
- small-scale civil works for the comfort, convenience, and safety of pedestrians;
- the need to manage vehicle speeds, in line with Safe System principles, to 30 km/h or less in areas used by pedestrians;
- traffic-calming strategies for managing vehicle speed through villages and on local streets;
- safety tips, to promote pedestrian safety and amenity; and
- case studies from across the CAREC region that demonstrate common pedestrian safety issues, together with options for successfully addressing each one.

This manual was prepared under an Asian Development Bank (ADB) technical assistance grant, TA 9754 REG: CAREC Knowledge Sharing and Services in Transport and Trade Facilitation (Phase 2). Its production was administered and managed by the CAREC Secretariat team at ADB—Oleg Samukhin, Rebecca Stapleton, Pilar Sahilan and Ma. Cristina M. Pascual. Phillip Jordan, ADB road safety engineering consultant, wrote this manual and took the photographs, except where otherwise indicated.

I. Pedestrians—The Forgotten Road Users

A. Pedestrians

1. A pedestrian is generally defined as someone on foot, or in a toy vehicle or a wheelchair not capable of going faster than 10 kilometers per hour (km/h). Pedestrians include people of all ages, both sexes, all races, and all religions, and from all walks of life. Walking is an essential mode of transport: everyone is a pedestrian at some stage of every journey. Pedestrians are the largest group of road users, and they can be found on the road network at any time, day and night.

2. Pedestrians are also the most vulnerable road users, and inevitably the most severely injured in collisions with motor vehicles. In several Central Asia Regional Economic Cooperation (CAREC) countries,

pedestrians make up the largest group of road user fatalities—42% of the reported total in Azerbaijan, 40% in the Kyrgyz Republic and Tajikistan, and 29% in Mongolia (WHO 2018).

3. Road safety is a serious health issue across the CAREC region, and pedestrian casualties are a large part of this problem. And while detailed crash data may not be readily available in some CAREC countries, to guide investigators to high risk pedestrian sites, other methods are available to determine risk on roads. Road safety assessments, such as the international road assessment program (iRAP), provide the necessary evidence-base to support decision-making to improve pedestrian safety. Significant iRAP surveys have been carried out in CAREC countries, providing a wealth of information about the risks to various road user

Pedestrians are legitimate road users. They need environments that help them walk along, and across, roads.



Everyone is a pedestrian. Pedestrians include people of all ages, both sexes, all races, and all religions, and from all walks of life.



Pedestrians are road users. Pedestrians make up the largest group of road users in every country.

groups on these roads. The iRAP star ratings can guide a road authority to the roads that are most in need of improved safety, including improvements for the most vulnerable road users. A key message of this manual is the need for decision makers in road agencies across the CAREC region to adopt the Safe System, use available iRAP data and give high priority to the safety of pedestrians. This large group of road users has been forgotten for too long and continues to pay a high price for the mobility of others.

4. Historically, engineers and planners were focused on expanding their road and highway networks to facilitate trade (via trucks and buses) and help their country grow, and to assist private travel by those fortunate enough to have automobiles. As the number of motor vehicles has increased, especially in the major cities, there has been, and there continues to be, pressure to increase road capacity. Demand for increased international trade has led to calls for improved highways across the CAREC region.

5. While these requirements have occupied the attention of planners and engineers, other road users have often been overlooked. Pedestrians, who may not pay road taxes and who travel short distances, are often deemed less important to national transport needs.

6. A review of CAREC roads today would reveal many issues affecting pedestrian convenience and safety, such as the following:

- many pedestrian (zebra) crossings, although these are not well-respected by drivers;
- many zebra crossings in unsafe locations on wide (multilane), high-speed roads;
- intersection signals without pedestrian signals or crosswalk markings;
- insufficient pedestrian clearance times at signals;
- not enough pedestrian-operated signals (POSS) along busy roads;
- pedestrian overpasses and underpasses built where other forms of crossing would be more welcome by users;
- speed limits not set in compliance with Safe System principles;
- inadequate speed management and “traffic calming” on main roads through villages;
- insufficient traffic calming to manage speeds on local streets;
- too few pedestrian refuges, curb ramps, or curb extensions; and
- inadequate maintenance of pedestrian facilities (worn lines, missing signs, broken signals).



Pedestrians. Pedestrians can be found on all roads, at all times of the day and night.

7. But change is occurring as decision makers increasingly understand that unrestricted road expansion comes at a cost, and that ignoring the needs of pedestrians adds to the cost. The best cities are those that provide infrastructure designed for people, not vehicles. People want to live and work in cities that are hospitable and welcoming, with balanced transport networks. They use motor vehicles, but they do not want these vehicles to ruin their daily lives.

The best cities are those designed for people, not vehicles.

8. New road projects in urban areas and between cities are paying more attention to pedestrian needs. Where new roads pass through villages, thought is being given to ways that can best help the pedestrians. Design-stage road safety audits are raising pedestrian safety issues for discussion and resolution.

9. But even as the desire to resolve pedestrian issues is growing, problems still arise at the implementation stage. Too many new facilities are proving to be less than optimal for pedestrians. Signals are helpful in some places but are so inefficient in others that pedestrians ignore them. Some newly constructed pedestrian footbridges remain underused, while many new zebra crossings are ignored by too many motorists. Simple items such as curb extensions and pedestrian refuges are not

constructed where needed, possibly because decision makers continue to underestimate their value to pedestrians. It is time for engineers and planners to look more closely at the real needs of pedestrians and to seek safer, efficient, and practical facilities that really assist them. With this manual, the CAREC Program aims to help.

B. Who walks, where, and why?

10. Walking trips are made for a wide range of purposes. Social and recreational activities are most commonly cited (25% of the total); shopping (14%), work (12%), and education (8%) are also mentioned (Land Transport New Zealand 2007). People are pedestrians for many reasons. Some are too young to drive, and many others do not yet own a car. These people travel medium to long distances by minibus, bicycle, motorcycle, or animal-drawn cart. Walking is their short-range option.

11. There are more vehicle–pedestrian collisions in low- and middle-income countries (LMICs) than in high-income countries. This is partly because motorization levels are lower in LMICs (fewer people own cars, so more people walk), and also because traditional transport planning in these countries tends to overlook pedestrians when providing for motor vehicles. In countries with good road safety records over the past 30 years or more, pedestrians and other vulnerable road users are explicitly included in transport planning. Those countries have long recognized the need to consider the mobility and safety needs of all their citizens and have broadened their planning objectives accordingly.

12. Walking is good for individuals and good for communities. Individual fitness improves when people walk instead of using motor vehicles, no matter how short the journey. Community well-being is heightened when more people walk because streets are safer and more congenial. And making more trips by foot, instead of using cars, helps reduce air pollution, noise, and disturbance in cities and towns. Governments worldwide now recognize the overall health benefits of walking, and some actively promote and fund programs to get people to walk more. There has been, and continues to be, a major shift in urban transportation from moving vehicles to moving people.

13. Pedestrians are now recognized as important road users for the following reasons:

- All journeys begin on foot. Everyone is a pedestrian at some stage of every journey.
- Pedestrians are the largest group of road users.
- Walking improves health and well-being.
- Walking costs little and generates no negative impact (no noise, no emissions).
- Walking is an essential part of most journeys, by public or private transport.
- Walking accounts for more than 25% of all journeys, and almost 80% of journeys of less than 1,500 meters.
- For short trips of up to about 1 kilometer (km), and especially in busy city centers, it is often quicker and easier to walk than to use a motor car with its associated parking issues.
- Walking is good for people and it is good for communities. Streets are safer with people in them.

14. A key element of this shift has been the provision of pedestrian facilities that promote and ensure inclusive mobility. Improved safety for vulnerable road users is highlighted in *Safely Connected: A Regional Road Safety Strategy for CAREC Countries, 2017–2030*, endorsed by the CAREC countries (ADB 2017). Guided by this strategy, the countries are looking at ways to make walking safer and more enjoyable for all their citizens.

There is a major shift in urban transportation from moving vehicles to moving people.

C. Why some people do not walk

15. Some people walk because they have no choice. Others walk because their trip is short and localized. Still, others walk for exercise. But some people do not walk, and they are often forgotten by transport planners. No one asks them why they do not walk, and because of this, their travel needs can be easily overlooked. Some planners have mistakenly concluded that these people are accommodated within the current planning regime. But the truth is quite different. One study (Land Transport New Zealand 2007) reported that shortcomings in the physical road environment are a major deterrent to walking, and that people decide not to walk for the following reasons:

- missing footpaths (or sections of footpath);
- tripping hazards (due to uneven, broken, or slippery walking surfaces);
- blocked footpaths (due to street furniture, overgrown vegetation, or illegal parking);
- greater walking distances (caused by road layouts, pedestrian fencing, footbridges, and subways);
- a lack of continuous pedestrian routes;
- no suitable crossings (allowing busy roads to sever communities);
- speeding traffic, fumes, and noise;
- poor streetlighting;
- lack of shade (for hot days) and lack of shelter (during inclement weather); and
- lack of rest areas and seating.

16. The study also found several social deterrents to walking, including the following:

- a belief that pedestrians have low social status, especially compared with car drivers;
- a concern that motorists do not understand the rights of pedestrians, and do not respect the road rules affecting pedestrians;
- concerns about collisions with motor vehicles because of these factors; and
- fear of being attacked in isolated, dark, or risky areas.

17. The message is clear, and many road authorities across CAREC are beginning to provide better infrastructure and amenities for pedestrians, knowing that this can lead to

- reduced pedestrian trauma;
- improved urban environments;
- reduced traffic congestion;



Vulnerable. Pedestrians, young and old, male, and female, are vulnerable to serious injury in a collision.

- environmental enhancements; and
- health and well-being for all.

18. A major problem for pedestrians is high vehicle speed. Higher driving speeds reduce predictability for pedestrians and make a driver less able to control the vehicle and to negotiate and maneuver around obstacles and other road users. Higher speed increases the distance a vehicle travels while the driver reacts to a potential collision, and extends the braking distance, thereby reducing the time available to avoid the collision.

19. More importantly, the probability of injury and the severity of injuries that occur in crashes increase exponentially with vehicle speed—to the power of four for fatalities, three for serious injuries, and two for casualties. Fundamental to the Safe System is minimizing energy transfer in collisions so that the resultant harm is minimized. The Safe System seeks

to achieve an environment in which impact speeds during a collision between a pedestrian and a motor vehicle are controlled to 30 km/h or less. Pedestrians struck at 30 km/h, on average, have a 10% probability of death, and at 40 km/h, a 25% probability of death; at 50 km/h, 55% of pedestrians can be expected to die from the impact. At relatively low-impact speeds, even crashes involving younger pedestrians can result in serious injury, but injuries to older pedestrians are likely to be more severe. Redressing this imbalance requires everyone managing the road network (engineers, designers, managers, police, and maintenance workers) to refocus on their work and on their “customers.” They need to put themselves in the shoes of the pedestrians and to design road networks for all road users. Pedestrians should be given the facilities they need, where and when they need them. CAREC roads will be better and much safer for it.

20. This manual outlines engineering and planning aspects for CAREC road agencies to consider as they strive to provide practical facilities that better serve their pedestrians. It is for use by all who are engaged in planning and designing road projects across the CAREC region. It is time to give pedestrians better and safer facilities. This manual is a start.

Careful planning, with adequate resources, can improve pedestrian safety and urban environments across CAREC.

II. Planning for Pedestrian Safety

A. Engineers have an important role in pedestrian safety

21. A wide variety of organizational and institutional issues have shaped the CAREC road environment over many years. In too many places, walking is now difficult and hazardous. Many towns and cities across the CAREC network have too many main roads that divide communities and serve as major obstacles for pedestrians. In extreme cases, pedestrians build their lives around what lies on their side of those “barriers.”

22. To compound matters, pedestrians still do not have a collective voice to lobby for better facilities. Engineers must recognize this need and take preemptive action on the pedestrians’ behalf. Engineers are responsible for designing, constructing, and maintaining the road network. They decide what traffic controls will be installed, and they manage the maintenance of those controls. The decisions engineers make therefore greatly affect pedestrian safety. Across much of the CAREC road network, there are too few safe pedestrian facilities. More can be done to help pedestrians, and to make cities more livable for all.

B. Adopting the Safe System to make roads more pedestrian-friendly

23. The Safe System approach to road safety was adopted by the United Nations as the basis for the Decade of Action Plan (2010 to 2020) and has since been endorsed within the Stockholm Declaration (See Appendix 3). The Safe System is the guiding approach used now by international stakeholders and major development banks in their global efforts to improve road safety and reduce road trauma. It is based on the premise that road crashes are both predictable and preventable, and that it is possible to move toward zero road deaths and serious injuries. This requires a fundamental rethink of the governance and implementation of road safety policy. The Safe System approach marks a shift from a focus on crash reduction to the elimination of death and serious injury. The core Safe System principles are:

- Fatal and serious injuries on the road are not acceptable. Road users have the right to travel safely, and this right cannot be traded for other gains (such as traffic capacity or efficiency).
- Humans are fallible, they do not make correct decisions all the time. Human error is inevitable meaning that crashes are inevitable.
- Humans are vulnerable. As roads users, they have limited tolerance for energy in a crash before it becomes a fatal or serious injury. Fundamental to the Safe System is minimizing energy transfer in collisions so that the resultant harm is minimized.

24. In the Safe System, there is a shared responsibility for road safety between the road network managers and the road users. The Safe System aims to develop a road transport system that is better able to accommodate human error by providing a safe operating environment, despite human fallibility, and providing effective post-crash care.

25. Most CAREC countries have a national road safety strategy, with a road safety action plan giving year-by-year direction to national road safety efforts. Among the most important improvements in pedestrian safety that can be introduced in any country is to ensure that pedestrians get high priority in the action plan, and that an adequate budget is provided to have the initiatives implemented.

26. A good outcome for pedestrians in a city, region, or country is accomplished when engineers and planners

- put themselves in the shoes of the pedestrians and focus on their road safety needs;
- keep in mind the needs of pedestrians under all conditions;
- focus also on the specific needs of the four high-risk groups of pedestrians (discussed in the next chapter);
- embrace the Safe System, and manage speeds in areas frequented by pedestrians to 30 km/h or less;
- are thorough in their critical safety thinking, and realistic and practical in their decisions; and
- keep relevant standards and guidelines in mind while remembering that compliance with these does not always guarantee safety for the pedestrians.

Figure 1: A Representation of Mobility vs. Land Access

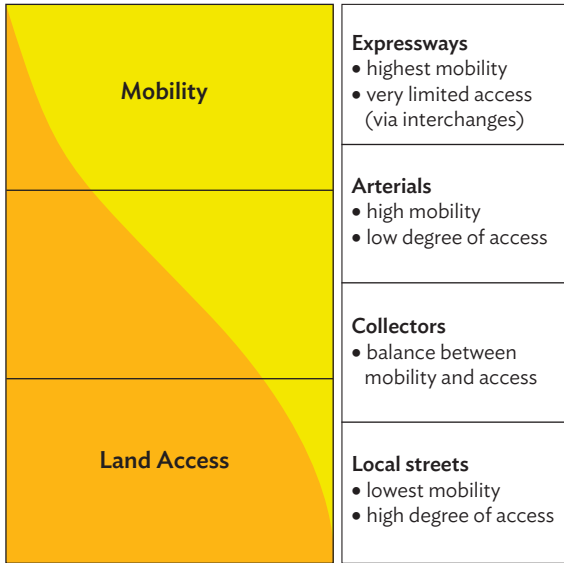

Source: AASHTO (2004).

C. Planning for pedestrians

27. Roads have two basic functions: one is to facilitate the movement of through traffic (a “mobility,” or movement, function), and the other is to support adjoining land use (an “access,” or place,

function) (Figure 1). The functions roads serve determine how they should be managed. For example, an expressway has the prime function of moving high volumes of traffic at high speeds. Expressways operate without intersections, and without abutting roadside development, bicyclists or pedestrians. They are the safest type of road per kilometer of travel because of this. On the other hand, for a street in a city center, with high numbers of pedestrian movements, the emphasis is on the place function.

28. On most streets and roads within a road network, these two functions often compete with each other; one can affect the service provided by the other. When traffic volumes are low, the two functions can coexist. But as traffic volumes rise, problems may emerge. High traffic volumes on a narrow street with many adjoining houses and apartments often lead to safety and environmental issues that require intervention. A highway passing through a village can create such issues when traffic volumes go up, especially if speeds are not managed in keeping with the residential function of the village.

29. Effective traffic management requires making decisions about the movement and access functions for a given road. The concept of a road hierarchy was developed to guide planners in allocating functions to roads in the network. An agreed road hierarchy allows engineers and planners to think consistently about the purpose of each road in their network.

Figure 2: Hierarchy for Considering Solutions

- Reduce traffic volume on the roadway
- Reduce traffic speed on the roadway
- Reallocate space on the road/corridor to pedestrians
- Provide at-grade crossing treatments (such as POS)
- Improve pedestrian routes on existing “desire lines”
- Create new pedestrian routes on new alignments, together with grade separation

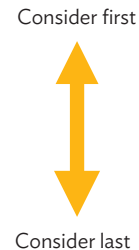

POS = pedestrian-operated signal (crossing).
 Note: Desire lines are routes that pedestrians wish to take.
 Source: Land Transport New Zealand (2007), page 5.2.

30. How can modern planners and engineers help pedestrians safely negotiate these roads without disrupting traffic movements too much at the same time? The interrelationship between infrastructure and vehicle speed is a critical factor in pedestrian protection. Roads are conduits for traffic movement, but there is a growing international trend toward an integrated and holistic approach to providing environments that are not hostile to pedestrians. Many jurisdictions have been rethinking their road networks, giving more attention to nonmotorized users and gaining a better understanding of how safety can be improved, particularly in urban areas. Separation (temporal and spatial) or treatments that support a low-speed environment for motor vehicles are currently the best means of achieving safe outcomes.

31. A hierarchy of potential treatments, such as that shown in Figure 2, can help engineers and planners establish a preferred option for improving the road or corridor and assist pedestrians.

32. Reducing traffic volume and speed has the highest priority, as it not only benefits pedestrians but can also improve road safety and air quality, and reduce the noise level, thus enhancing the environment for others in the area. It also contributes to the less quantifiable quality of the streetscape. However, this option is difficult to achieve, as traffic will need to go somewhere, and speeds will be reduced only after serious intervention by enforcement agencies. For streets that are toward the lower end of a road hierarchy (such as local streets and collector roads), it is possible and practical to use traffic-calming devices to slow down traffic and, in some cases, to deter unnecessary through traffic. Good traffic calming can benefit pedestrians while improving the urban environment. Chapter 7 of this manual outlines traffic-calming strategies and gives examples of common calming devices that are effective in lowering vehicle speeds. Reductions in vehicle speeds, brought about by traffic calming, can significantly reduce pedestrian trauma. The Safe System guides engineers to work toward 30 km/h speeds in areas used by pedestrians.

33. New route alignments and grade separation are listed last in Figure 2, as they typically divert pedestrians from their desired path to create a better environment for motor vehicles. This treatment option is usually the least favored among pedestrians, as it provides better access for motor vehicles at the expense of pedestrian convenience.

Figure 3: Probability of Fatal Injury for a Pedestrian when Struck by a Motor Vehicle

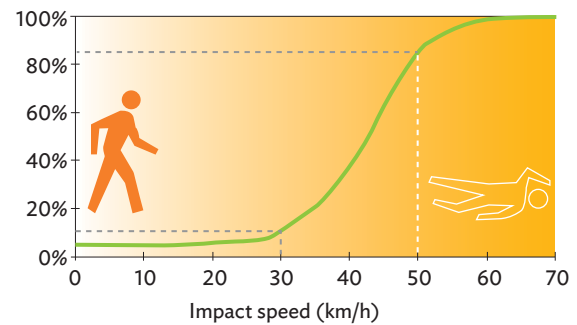

km/h = kilometer per hour.
Source: GRSP (2008), page 5.

D. Ensuring good enforcement

34. This manual focuses on the physical road environment and how it can be improved to promote pedestrian safety. It is intended mainly for engineers, planners, and decision makers in CAREC road agencies. But other stakeholders also have important roles in pedestrian safety. Among the most important stakeholders are the traffic police, who are responsible for enforcing road rules. National road rules must be enforced well, and consistently, if pedestrian facilities are to work successfully and pedestrians are to gain full benefit from them.

35. Police enforcement is an essential part of creating and maintaining a safe environment for all transport modes. It is essential for drivers to know that the police will enforce the road rules fairly and equitably, including the road rules that enhance pedestrian safety. Well-publicized enforcement campaigns must be used to discourage speeding, and drink-driving, and to make drivers aware of the need to share the road with all road users in compliance with national road rules. The enforcement of vehicle parking rules on footpaths is a simple but necessary activity to keep these open as intended. Very importantly, by enforcing the road rules fairly and consistently, the traffic police help to build a sense of right and wrong among road users, lending credibility to public awareness campaigns, school education programs, and traffic control devices.

Good, consistent police enforcement is vital for pedestrian safety.

36. Police enforcement of pedestrian facilities should, for safety's sake, be focused more on drivers than on pedestrians. Although some pedestrians disobey traffic signals, or cross away from a crossing,

such offenses are relatively minor compared with the failure of drivers to give way at a zebra crossing or to stop at a red signal. Good, consistent police enforcement increases driver awareness of the need to share the road according to the road rules. It builds trust between road-user groups and, in turn, can reduce pedestrian trauma. Helpful information about effective enforcement is available from the Global Road Safety Partnership's Road Policing Team at www.grsproadsafety.org.

III. Special Groups of Pedestrians

37. All pedestrians need the careful attention of road authority engineers. It can be easy for an engineer, when inspecting a site, to believe that everyone using the site, just like him or her, is a professionally qualified, young or middle-aged person in good health and with a solid understanding of the road rules. But not all pedestrians are the same. Young, old; energetic, tired; educated, not so educated—all pedestrians must be considered. Engineers need to put themselves in the pedestrians' shoes to find out how to best provide for them. That is difficult to do, but the task can be made manageable if those engineers were to walk the site (day and night), talk

with stakeholders, and work with a range of colleagues, some of whom may have differing views.

38. In addition to the general needs of all pedestrians there are four groups considered to be most “at risk” on the roads. These four groups of pedestrians are as follows:

- children (typically 4–12 years of age);
- senior citizens (typically above 65 years of age);
- intoxicated pedestrians; and
- disabled pedestrians (on crutches or in wheelchairs, or sensory impaired).



Requiring special attention. Children, seniors, the intoxicated, and the disabled are the four groups of pedestrians requiring special attention on the road.

39. This chapter gives a summary of some of the characteristics and the special needs of these groups. Appreciating these characteristics is an important step for engineers (and others) toward understanding what is really needed to help these groups of pedestrians within the confines of the road and traffic network.

A. Children

40. Child pedestrians are a large road-user group that faces challenges different from those that confront adult pedestrians. They are different from adults, not only in physical build but also in developmental maturity. As nondrivers, they rely heavily on walking trips to go to and from school and for independent travel within their community.

41. Observations of children have led to the understanding that child pedestrians, particularly those below 10 years of age, live in a conceptual world unlike that of adult pedestrians. They have a fragmented understanding of road rules, their level of attention fluctuates, they are easily distracted, and their knowledge of traffic devices is limited (Ogden 1996). They trust that others will protect them, and some are overconfident in some circumstances. Their restricted abilities and lack of experience place them at greater risk of involvement in collisions, and therefore of injury. Fortunately for child pedestrians, their injuries tend to be less serious than those suffered by elderly pedestrians.

42. The journey to and from school is one of the most common trips for children, but it is not their only one. They often go to friends' houses after school, to nearby shops, to parks and play areas. According to some

studies, children tend to get into twice as many reported collisions on their way home from school than on their journey to school. There are various explanations for this trend, but it may be that the routes they take to play with friends after school are different from their daily routes to school. The studies also reveal that most child pedestrian crashes occur near the child's home, most involve the child running across the road, and most do not occur at or near a pedestrian facility. Usually, the child did not see the vehicle, or saw it too late.

43. These patterns in child-pedestrian collisions highlight the need for road authorities to take an area-wide view of the safety of pedestrians, both children and adults; to calm traffic in local streets and areas (lower speeds are better for safety); and to introduce more small-scale civil works (curb extensions and the like) to reduce risk across the network for children and all others.

44. The right-hand column in Table 1 offers a glimpse of some design features that engineers need to consider as they decide, plan, design, and install a pedestrian facility, taking child pedestrians into account.

Children are not small adults. They do not have the maturity to use the road network safely. Children under 10 years should not be allowed near roads without adult supervision.



Children. Children are not “small adults.” They lack experience and judgment in traffic and require adult supervision near roads until at least the age of 10.

Table 1: Design Considerations for Child Pedestrians

Characteristic of Child Pedestrians	Consequences	Considerations
Shorter height	Reduced ability to see over the tops of objects	Sight lines and visibilities Curb extensions
Less able to accurately judge speed and distance	Inopportune crossing movements	Sight lines kept open Pedestrian fencing Provision of crossing facilities Part-time crossings for school trips Adult supervision
Unpredictable, impulsive actions	Dart-outs Unexpected movements Poor selection of routes and crossing points	Sight lines kept open Pedestrian fencing Lateral separation from cars Provision of footpaths Controlled traffic speeds Adult supervision
Reduced peripheral vision	Reduced ability to scan the environment	Crossing locations Trip hazards Sign legibility Curb detection
Limited attention span and cognitive abilities	Inability to read or understand warning signs and traffic signals	Positive directional signage “Legibility” of streetscape Use of symbols

Source: Land Transport New Zealand (2007), Appendix A1-2, modified by the ADB road safety engineering consultant.

45. The following are useful tips for enhancing the safety of child pedestrians:

- Children do not reach “traffic maturity” until the age of 10 (at least).
- Under 10 years of age, children are incapable of selecting safe gaps in traffic. They need adult supervision.
- Children do most of their walking during daylight hours.
- Pedestrian-operated signals (POSs) are easier for them to understand than zebra crossings, but they still need adult supervision when crossing busy roads.
- Employing adult supervisors at crossings on the journey to school should be considered.
- Sight lines should be kept open, so that drivers can see them from as far away as practical. (Be seen, be safe.)
- Open, wide, and smooth footpaths with curb ramps and curb extensions should be provided to minimize trip risk, and to maximize sight lines.

- Developing a part-time crossing for use on the journey to and from school should be considered.

B. Senior citizens

46. Walking is an essential part of many trips. However, the dominance of motor vehicles, coupled with high traffic speeds and volumes on many roads, places demands on the adaptability of senior pedestrians. As people get older, their physical, cognitive, and sensory abilities tend to deteriorate. The changes happen at different rates and in different ways for everyone. Those responsible for providing pedestrian facilities must recognize this fact and provide facilities that do not prohibit use by seniors.

47. This section is about pedestrians who are seniors (above 65 years of age) but are not necessarily



Senior citizens. Elderly pedestrians welcome the opportunity to walk as it is one of their best forms of exercise. However, if struck by a moving vehicle, they tend to be more severely injured than younger pedestrians and they take longer to recover. They benefit from civil works (curb ramps, curb extensions, bridges over drains, and streetlights) and, like all other pedestrians, they enjoy good pedestrian signals (especially pedestrian user-friendly intelligent, or PUFFIN, signals).

disabled. There are three groups of disabled pedestrians (detailed below), and some people in those groups may be seniors, but many will not be. The seniors covered in this section are typically fit and active for their age, but when compared with pedestrians in other age groups, they do have some different characteristics.

48. Senior citizens usually have experience in all sorts of traffic conditions, gained over several decades. They tend to walk in the day as well as at night (children, on the other hand, tend to make fewer trips after dark). They often walk more slowly than young adults, and for different purposes. Regular walking is an especially valuable form of exercise for senior citizens, but as age increases so do the consequences of collisions with motor vehicles. Although crash rates among senior pedestrians tend to be lower than the rates for other groups, the injuries that result are generally more severe.

49. The good news all-around is, by providing facilities that serve seniors well, a road authority will also serve most disabled pedestrians. And by providing for disabled pedestrians, the road authority will also greatly assist seniors. This is best summed up in the Swedish “Vision Zero” concept relative to older pedestrians, which states that

- children, senior citizens, and disabled persons are to be normative in the design of the road transport system;

- different categories of road users should be separated, to minimize the risk of collision; and
- road infrastructure improvements and overall vehicle speed reductions should be mandatory so that no user is exposed to mechanical forces above the threshold for producing serious injury (SWOV Institute for Road Safety Research 2017).

50. The right-hand column in Table 2 offers a glimpse of some design features that engineers need to consider as they decide, plan, design, and install a pedestrian facility, taking senior pedestrians into account.

51. Some tips to improve the safety of senior citizens are as follows:

- Wide, clear, and smooth footpaths should be provided.
- Paving materials that do not become slippery when wet should be used for footpaths.
- Streetlights should be installed along arterial roads and footpaths.
- Curb extensions are useful for senior citizens (and all pedestrians). (Be seen, be safe.)
- Curb ramps are essential. They assist all pedestrians but especially seniors, the wheeled disabled, and mobility-impaired pedestrians.
- Plenty of bridges should be provided over open drains.
- Refuge islands should be installed to help seniors cross local streets and collector roads.

Table 2: Design Considerations for Senior Pedestrians

Characteristic of Senior Pedestrians	Consequences	Considerations
Reduced range of joint motion	Slower walking speed	Crossing and clearance times Curb extensions
Eyesight issues, including reduced visual acuity and poor central vision	Reduced ability to scan the environment	Locations for time-separated crossings Curb detection Tripping hazards
Decreased agility, balance, and stability	Difficulties in changing levels	Provision of steps or ramps Curb height Gradients Handrails Surface quality, slipping
Increased fear for personal safety	Fear of using all or part of a route	Lighting Surveillance Traffic speed and density Lateral separation from cars Provision of footpaths
Slower reflexes	Inability to avoid dangerous situations quickly	Crossings that offer time separation
Reduced stamina	Shorter journeys between rests	Resting places and shelter
Reduced memory and cognitive abilities	More time needed for decisions Difficulties in unfamiliar areas	Consistency of devices Consistency of facilities

Source: Land Transport New Zealand (2007), Appendix A1-1, modified by the ADB road safety engineering consultant.

- PUFFIN crossings should be used to help seniors across busy roads. The overhead detector can increase the clearance time for the senior citizens that need the most help.

C. Intoxicated pedestrians

52. Pedestrians who have been drinking alcohol (and/or using other drugs) are at high risk of involvement in serious and fatal pedestrian crashes. Several studies from around the world have found that

- at least 25% of all adult pedestrian fatalities have blood alcohol concentrations (BACs) exceeding 80 milligrams per 100 milliliters;
- the BAC distribution of impaired pedestrians is skewed toward high BACs;

- the victims are predominantly male, and the crashes tend to occur at night;
- 43% of nighttime pedestrian fatalities have BACs of more than 0.15%;
- alcohol-related pedestrian crashes are related to social deprivation (particularly evident among indigenous people); and
- like drivers, pedestrians are at greater risk of being involved in a crash as their blood alcohol levels rise, but the BAC at which the risk curve starts to increase is higher for pedestrians.

53. The presence of alcohol (and/or other drugs) in the system impairs the ability of pedestrians to safely negotiate roads and traffic. Their reactions slow down, and their inhibitions are reduced. The risk of being involved in a fatal crash increases as more alcohol is consumed. But this road-user group, though smaller than others, presents challenges unlike those posed

by other groups of pedestrians and is a difficult group to either help or restrict. Most intoxicated pedestrians are male, and the collisions take place mainly at night. They are also thought to be less inclined to use crossings, and less likely to use them correctly. The risk of a collision anytime, but especially at night, becomes even greater as a result.

54. Some may have decided to walk after realizing they were too intoxicated to drive. Others may have been struck when crossing a road to get into a taxi or bus rather than drive. By choosing not to drive, these intoxicated pedestrians were alert and responsible enough to refrain from putting others at risk. There are laws against “drunk-driving” everywhere, but “drunk-walking” is not yet an offense. Introducing harsher laws and penalties for intoxicated pedestrians could make some of them decide to drive instead, and that would put more people at risk. It is a fine balance.

55. Changing this social/health problem would be difficult for engineers; that goal is for other professionals to pursue. But engineers can improve the road network to make intoxicated pedestrians as conspicuous as possible (particularly at night), as part of a general strategy of reducing an adverse

consequence of this social/health problem. Drivers do not want to collide with pedestrians; making intoxicated pedestrians more easily noticeable to approaching drivers is one way of reducing this risk. Improved streetlighting and selective use of pedestrian fencing, medians, refuge islands, curb extensions, and pedestrian signals (at intersections and midblock) are some treatments that can make intoxicated pedestrians safer near roads. When coupled with lower operating speeds, the effectiveness of all these devices is greatly increased.

56. The right-hand column in Table 3 offers a glimpse of some design features that engineers need to consider as they decide, plan, design, and install a pedestrian facility, taking intoxicated pedestrians into account.

57. The following are useful tips for improving the safety of intoxicated pedestrians:

- Intoxicated pedestrians are mainly a nighttime safety problem.
- Night inspections should therefore be done.
- Streetlighting should be improved in areas where intoxicated pedestrians are a known problem.

Table 3: Design Considerations for Intoxicated Pedestrians

Characteristic of Intoxicated Pedestrians	Consequences	Considerations
Unpredictable or impulsive actions, especially at night	Impulsive movements onto the road Poor selection of gaps, crossing points, and routes	Fencing Curb extensions Provision of footpaths Improved conspicuity, especially with streetlighting Traffic speed and density
Less accuracy in judging speed and distance, especially at night	Inopportune crossing movements	Provision of more crossing facilities Improved streetlighting
Limited attention span and cognitive abilities	Inability to find or focus on approaching vehicles, warning signs, or traffic signals.	Sight lines to and from the pedestrian Curb extensions Improved conspicuity, especially with lighting
Impaired ability to negotiate roads	Poor gap acceptance, especially after dark	Types of crossings to use Pedestrian refuges Streetlighting

Source: Asian Development Bank.

- For these pedestrians, who tend to cross roads anywhere, curb extensions can be helpful if they use them. All other pedestrians stand to benefit too. (Be seen, be safe.)
- If road widths permit, refuge islands should be constructed to help these pedestrians cross roads in stages.
- Prudent installation of fencing along the curb outside bars and hotels can prevent “dart-outs.”
- PUFFIN crossings can be used to help intoxicated pedestrians cross busy roads. The overhead detector can increase their clearance time if necessary.
- POSs equipped with audio-tactile devices will beep to prompt an intoxicated person to cross.



D. Disabled pedestrians

58. Crossing roads is particularly challenging for people with disabilities and can inhibit them from moving about on the streets. People with limited or no vision have difficulty knowing where to cross, and people in wheelchairs and those with limited mobility sometimes have trouble moving on and off crossings or completing their crossing in the time available. Various forms of disability affect the larger group referred to here as disabled pedestrians. Not all of these pedestrians are the same. Those with mobility impairments often rely on devices such as wheelchairs or crutches to move around. Others, while fully abled in a physical sense, may suffer from a sensory impairment such as deafness or blindness. These people have quite different needs.



Not all pedestrians—and not all disabled pedestrians—are the same. Different groups have different needs.

59. It is therefore useful to keep three broad groups of disabled pedestrians in mind: mobility-impaired (often walking with the aid of devices), wheeled (using wheelchairs to get around), and sensory-impaired (those with hearing or vision problems) pedestrians. The specific assistance required varies from one group to another.



Assisting the mobility-impaired. Mobility-impaired pedestrians tend to be slower and require more space in which to move. Some may use walking sticks or frames, while others may need only extra time.

1. Mobility-impaired pedestrians

60. Mobility-impaired pedestrians are commonly thought of as those using devices (canes, sticks, crutches, walkers, or prosthetic limbs) to help them walk. However, a large proportion of people with mobility impairments do not use any visually identifiable device. Some of them may suffer from restrictions on muscle movement (in their legs or backs), while others may have limited movement following a stroke. Pedestrians in this category need assistance, but they do not always appear so different from other pedestrians.

61. The right-hand column in Table 4 offers a glimpse of some design features that engineers need to consider as they decide, plan, design, and install a pedestrian facility, taking mobility-impaired pedestrians into account. Figure 4 shows the required path width for such road users.

Figure 4: Required Path Width for Users with Mobility Impairment

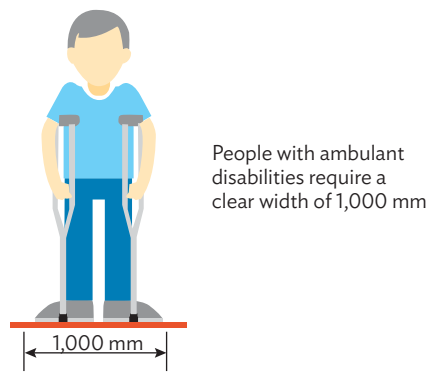

People with ambulant disabilities require a clear width of 1,000 mm

mm = millimeter.
Source: AUSTRROADS (2017c), page 17.

Table 4: Design Considerations for Mobility-Impaired Pedestrians

Characteristic of Mobility-Impaired Pedestrians	Consequences	Considerations
Extra energy expended in movement	Slower walking speeds	Crossing times Journey length Surface quality Curb extensions Refuge islands
Use of mobility aids	Need for more physical space and good surface quality	Footpath width Footpath condition Obstructions Step depth Gaps/grates
Decreased agility, balance and stability	Difficulties in changing levels	Provision of steps/ramps Curb height Gradients Handrails Surface quality
Reduced stamina	Shorter journeys between rests	Resting places Refuge islands Shelter
Reduced manual dexterity and coordination	Reduced ability to operate complex mechanisms	Pedestrian-operated signals

Source: Land Transport New Zealand (2007), Appendix A1-2, modified by the ADB road safety engineering consultant.

62. Useful tips for enhancing the safety of mobility-impaired pedestrians are as follows:

- Smooth paths with a non-slip surface should be provided.
- Planners and engineers should see to it that there are no tripping hazards.
- Curb ramps are highly desirable. They assist all pedestrians, but especially those on crutches or using walking frames.
- Curb ramps should be made as wide as the crossing facility; their width should not be compressed.
- Curb extensions are useful for mobility-impaired pedestrians. (Be seen, be safe.)
- Bridges over open drains are essential; they should be at least 2 meters (m) wide.
- A continuous route, with no “squeeze” points (caused by bus shelters, lighting columns, or street furniture), should be provided.
- Streetlights should be installed along arterial roads and footpaths.
- PUFFIN crossings can be used to help the mobility-impaired cross busy roads. The overhead detector can increase their clearance times when necessary.

2. Wheeled pedestrians

63. There is a wide variety of wheelchairs and scooters available to assist the mobility of some disabled people. These include manual wheelchairs, motorized wheelchairs, and mobility scooters. Wheelchair and scooter users may legally use the pedestrian network, but their characteristics are quite different from those of pedestrians on foot. The network must function differently to take the needs of these wheeled pedestrians into account. The mobility aids vary in size, and designers should therefore refer to national standards (or the manufacturer) for this information, because it can have an impact on the design of paths or areas provided for wheeled users. Consultation with local community stakeholders can also yield useful information about the needs of users of wheelchairs and mobility scooters. Consultations with representatives of organizations of persons with disabilities are always useful. Much can be learned from the daily experience of real users.

64. These users need paths that are wide enough, flat enough, and smooth enough for comfortable use, and with enough space for safe maneuvering. Designers should therefore seek to provide paths that are

- at least 1,800 millimeters (mm) wide (to allow two wheelchairs to pass each other);

- reasonably flat, with slopes of less than 3% in general, and only up to 5% for distances of less than 15 meters (m); and
- all-weather paths, suitable for wheelchair and scooter tires. Because other pedestrians also use these paths, the surface is important, and must be antislip even when wet.

65. Where the gradient of a path is 3%, level rest areas at least 1,200 mm long should be provided at 25 m intervals (or less). If the grade is 5%, the interval should not exceed 15 m. (Interpolation should be done between these two grades.) Landings are not required on gradients of less than 3%. Paths with a gradient steeper than 5% are considered as ramps.

66. The ground beside a pedestrian path should be within 25 mm of the level of the path, and if the adjacent ground has a steep slope, a curb of 65–75 mm should be used to guide the users of prams and wheelchairs and those with impaired vision. Where steep slopes exist, handrails are desirable. Wheelchair and mobility scooter users do require more space than other people to maneuver. International standards require a maneuvering space of at least 2.07 m by 1.54 m for a wheelchair or mobility scooter to make a 180° turn.

67. Figure 5 shows the radius of turn for a wheelchair when wheels are moved in opposite directions and when a pivot is done about a locked wheel. The radii represent the swept path of the wheelchair. Designers must therefore provide sufficient clearance from the swept path to fixed objects to allow for variance in the location at which the rider chooses to begin the turn, and to make the operating conditions safe and comfortable.

Figure 5: Wheelchair-Turning Envelope

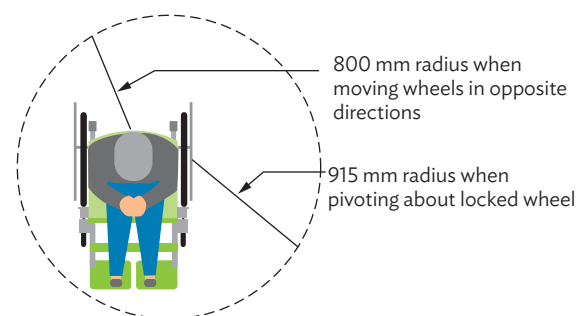

mm = millimeter.

Source: AUSTRROADS (2017c), page 16.

This clearance is necessary to avoid the risk of damage to the wheelchair and to street infrastructure, and injury to the wheelchair rider.

68. The right-hand column in Table 5 offers a glimpse of design features that engineers need to consider as they decide, plan, design, and install a pedestrian facility, taking wheeled pedestrians into account. Figure 6 shows the required path widths for various wheeled users.

69. The following are useful safety tips for wheeled pedestrians:

- Smooth paths with suitably graded curb ramps should be provided.
- Curb ramps should be made as wide as the marked crosswalk or crossing facility; their width should not be compressed.

- A continuous route, with no “squeeze” points (caused by bus shelters, lighting columns, or street furniture), should be provided.
- Streetlights should be installed along arterial roads and footpaths.
- PUFFIN crossings can be used to help wheeled pedestrians cross busy roads. The overhead detector can increase clearance times.
- At overpasses and underpasses, 24-hour lifts should be provided (and maintained). Alternatively, suitably graded ramps with suitable antislip surfacing and lighting may be provided.

3. Sensory-impaired pedestrians

70. Sensory impairment is often mistaken for complete loss of at least one sense, but for most people, partial loss is more common. Pedestrians’ abilities are most often affected by sight impairment, followed by

Table 5: Design Considerations for Wheeled Pedestrians

Characteristic of Wheeled Pedestrians	Consequences	Considerations
Increased susceptibility to the effects of gravity because of the wheels	Slower speeds traveling uphill, faster speeds on level surfaces or traveling downhill	Route gradients Upstands/steps Sudden changes in gradient Interaction with walking pedestrians
Increased “effective width” of the pedestrian because of the width of the wheelchair/scooter	Wider path required, to pass others	Path widths (including crosswalks across roads) Street furniture placement Passing places on narrow routes Larger waiting areas
Reduced agility	Increased turning radius (and turning circle)	Places to turn around Horizontal alignments Surface quality
Reduced stability	Greater potential for overbalancing	Surface quality Sudden changes in gradient Cross-fall Maximum forward/side reach to push buttons at signals
Seated	Lower eye level	Location of push buttons at signals Position of signs Sight lines and landscaping Curb extensions

Source: Land Transport New Zealand (2007) Appendix A1-3, modified by the ADB road safety engineering consultant.

Figure 6: Path Widths for Various Wheeled Users

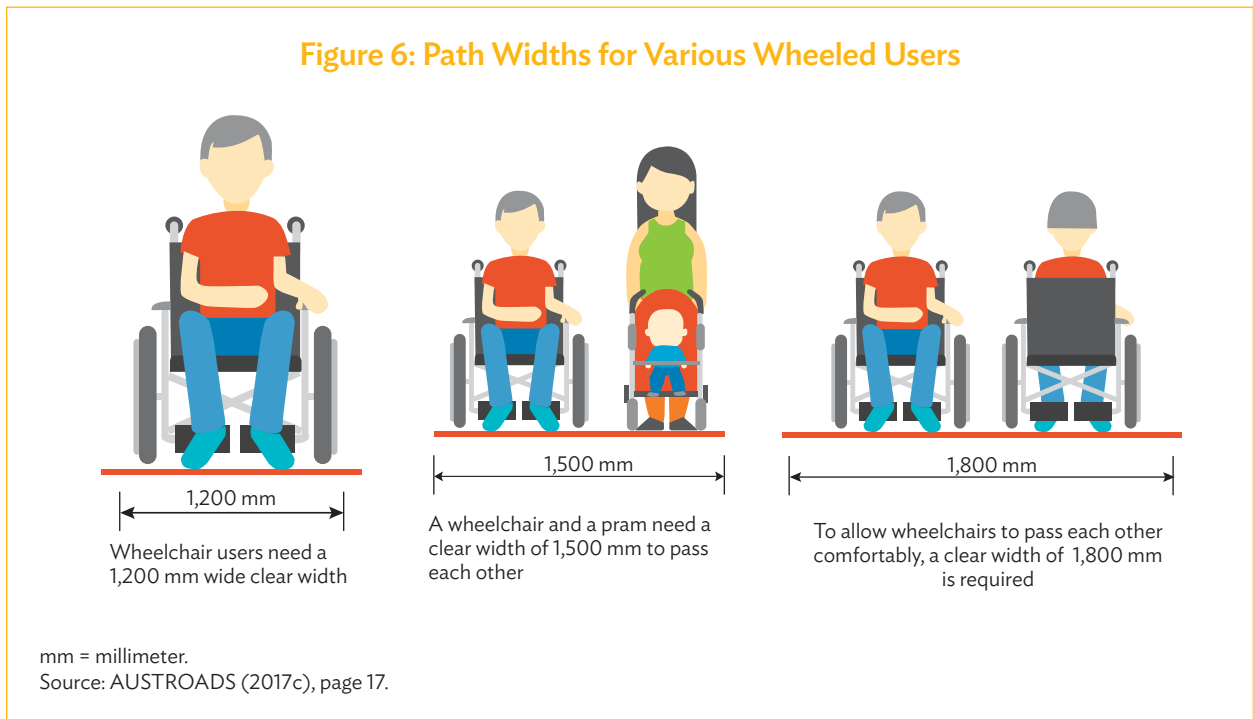

Assisting wheeled pedestrians. Wheeled pedestrians need flat, smooth paths, well-graded curb ramps, cut-through medians, and space to maneuver past street furniture.



Assisting the visually impaired. Visually impaired pedestrians can have serious difficulties when using the road system, as they will not know when they are approaching points of conflict. The infrastructure can assist them through the correct use of tactile ground surface indicators (TGSIs), audio-tactile signals, and small scale civil works especially curb ramps and curb extensions.

hearing loss. Many of those who are termed “blind” have some degree of sight or of contrast resolution. But this may not be enough for them to see, decide, and act in time on the roads. Visually impaired pedestrians need help to walk along footpaths without tripping, to find a suitable crossing point, and to select a suitable gap in the traffic. Guide dogs, white canes, and adult assistants are extremely useful, but some visually impaired people do not have access to such help. These people get around by making use of their other senses (acutely attuned hearing or touch) and relying on safe infrastructure to assist them.

71. Hearing-impaired pedestrians—even those using hearing aids—tend to compensate for their lack of hearing by making full use of their sight. Pedestrians with both sight and hearing impairment are perhaps the most in need of assistance in getting around. Tactile ground surface indicators (TGSIs), when applied consistently, can be of great help to these pedestrians. Audio-tactile push buttons at pedestrian signals are also useful.

72. The right-hand column in Table 6 offers a glimpse of some design features that engineers must consider as they decide, plan, design, and install a pedestrian facility, taking sensory-impaired pedestrians into account.

73. Useful tips for enhancing the safety of sensory-impaired pedestrians are as follows:

- Smooth paths, with no tripping or snagging hazards, should be provided.
- Suitably graded curb ramps should be built.
- Curb ramps should be made as wide as the marked crosswalk or crossing facility; there is no need to compress their width.
- Cut-through paths, flush with the road, should be constructed in refuges and medians.
- At each decision point, and at each conflict point, TGSIs should be installed to alert the visually impaired.
- A continuous route, with no “squeeze” points (caused by bus shelters, lighting columns, or street furniture), should be provided.

- Streetlights should be installed along arterial roads and footpaths.
- PUFFIN crossings can be used to help sensory-impaired pedestrians cross busy roads. The overhead detector can increase clearance times.
- PUFFIN crossings with audio-tactile push buttons can inform the visually impaired when to cross, and the tactile device will assist the hearing-impaired.

74. These four special groups of pedestrians—children, seniors, the intoxicated, and the disabled—are overrepresented in pedestrian crashes. They warrant detailed attention during all stages of road projects, and they deserve appropriate facilities. As the following chapters will show, these groups can be assisted with carefully designed and located pedestrian facilities. The skill and judgment required for this task should not be underestimated. Remembering that there are special groups of pedestrians, and having empathy with their needs, is an excellent starting point.

Table 6: Design Considerations for Sensory-Impaired Pedestrians

Characteristic of Sensory-Impaired Pedestrians	Consequences	Considerations
Reduction in hearing	Missing audible clues to traffic	Need to reinforce visual information Audio-tactile pedestrian facilities
Reduction in vision	Reduced ability to scan the environment	TGSIs on paths Curb detection Audio-tactile pedestrian facilities Trip hazards Consistency of streetscape
Severe visual impairment	Use of guide dog or tactile feedback, or both, to navigate	Streetscape legibility TGSIs on paths Audio-tactile pedestrian facilities
Lack of contrast resolution	Reduced ability to distinguish objects	Audio-tactile pedestrian facilities Sign legibility Small changes in level Trip hazards

TGSI = tactile ground surface indicator.

Source: Land Transport New Zealand (2007), Appendix A1.3, modified by the ADB road safety engineering consultant.

IV. Segregation, Separation, and Integration

A. Considering the options

75. Engineers are responsible for providing roads and highways that are as safe as practical for all road users. This is an important job, requiring qualified and experienced professionals to ensure that the needs of all road users are met. But some needs compete with others, and it is difficult to satisfy all needs equally. Perhaps some of the most challenging tasks involve the trade-off between pedestrians and motor vehicles.

76. An expressway, for instance, should have no crossings on it: all pedestrians should go over or under. A local street may not need a formal crossing but will benefit from traffic calming, curb extensions, and refuge islands. The classes of roads in-between are where the challenges lie. Collector or sub-arterial roads are also helped by civil works like curb extensions, while a zebra crossing may be needed in some situations, or pedestrian-operated signals in others. Arterial roads with higher traffic volumes, higher speeds, and smaller gaps between vehicles are where the choice and placement of crossing facilities becomes a critical matter.

Engineers should put themselves in the shoes of the pedestrians, and design facilities that best suit their needs.

77. All the options available can be especially difficult to consider in a problem location where collisions involving pedestrians are the main issue. We are all pedestrians, but some agencies and engineers still feel that pedestrians can be served only with facilities that do not hinder the normal flow of road traffic. If pedestrian safety is to be improved across the CAREC region, and if the amount of road trauma involving pedestrians in CAREC countries is to be reduced, it is necessary to rethink this approach to transport planning and highway design.

In short, it is useful to have a simple strategy that can help engineers focus on their options for assisting pedestrians. This chapter outlines that strategy.

78. The pedestrian management strategy can be summarized in three words: segregation, separation, and integration.

- **Segregation** is where pedestrians are set apart from motor vehicles. Pedestrian malls are at one end of this range (motor vehicles are prohibited or restricted in malls); expressways are at the other (pedestrians are prohibited from expressways).
- **Separation** gives pedestrians their own space or time on the road. Pedestrian overpasses and underpasses, footpaths, pedestrian refuges, central medians, and curb extensions provide spatial separation for pedestrians. Pedestrian (zebra) crossings, POSs, PUFFIN crossings, pedestrian light-controlled (PELICAN) crossings, and intersection signals offer them time separation.
- **Integration** shares road space between pedestrians and motor vehicles, within agreed rules. This part of the strategy applies to most of the road network. In local streets, for example, people can cross the road where they wish but they are expected to give way to motor traffic except at marked crossings. If a pedestrian is struck by a car on any street, and away from a crossing, it is invariably the pedestrian who is deemed to be “at fault.” The management of vehicle speeds is critical to pedestrian safety within the integration element of the strategy.

79. This manual focuses on the second and third parts of this strategy—separation and integration. CAREC road authorities most commonly work within these elements of the strategy. It is less common for them to plan or design expressways or pedestrian malls.

80. In short, the following may be said about the pedestrian management strategy:

- Segregation is usually addressed in transport planning. Expressways and malls are planned and designed for reasons other than pedestrian safety, usually for nationally strategic reasons and commercial reasons.

- Separation is the focus of this manual because it requires considered decisions about which pedestrian facilities to apply to which location to best give pedestrians their own space or their own crossing time.
- Integration is covered in this manual, in the chapters on civil works and traffic calming, which are both important for the overall well-being of pedestrians in urban environments.

81. Each treatment in the strategy has its advantages and disadvantages. No device or strategy is 100% safe for all pedestrians, all the time. Elderly, young, intoxicated, and disabled pedestrians all have differing safety needs and differing capabilities. It is therefore important for safety that a strategy be adopted only after a balanced consideration of the needs and capabilities of the pedestrians at a given location. Judgment is needed for each location.

B. Segregation

82. Segregation involves keeping pedestrians and motor vehicles apart, by the class of road. This involves expressways, on which pedestrians are prohibited, at one end, and pedestrian malls and streets, where motor vehicles are prohibited most of the time, at the other. When pedestrians are segregated from motor vehicles there is (almost) no risk of collisions.

Segregation of vehicles and pedestrians is rarely done for pedestrian safety alone.



Segregating pedestrians from traffic. The segregation element of the pedestrian strategy involves keeping motor vehicles and pedestrians apart. Expressways are for motor vehicles; malls are for pedestrians.

83. However, expressways are expensive roads, designed and built for long-distance high-speed travel by motor vehicles. And pedestrian malls are usually planned, designed, and constructed to serve commercial needs. The streets are generally small and closed to traffic to attract more foot traffic into nearby shops and businesses.

84. When confronted with a pedestrian problem on an urban street, it is unlikely that an engineer will be able to adopt segregation as a viable strategy. In a very few instances, a new expressway may be under construction nearby, and scheduled to open soon, so that much of the traffic will be rerouted away from the pedestrian problem site. In some locations in busy commercial areas, it may be feasible to close a problem street to traffic and convert it into a pedestrian mall. Such changes can be expensive because of the urban design involved, and they do affect traffic movements in the area. A pedestrian mall is not commonly created for safety reasons alone.

C. Separation

85. The separation of motor vehicles and pedestrians can take place in either time or space. This part of the strategy offers temporal (time) separation and spatial (space) separation options.

86. Temporal separation keeps pedestrians apart from motor vehicles in time. An example of this is a set of POSs: when the pedestrian pushes the button to call up the Walk interval, the signals go red for the motor vehicles, giving the pedestrian a set period of

time for crossing the road without any conflict from a motor vehicle. The drivers are relied on to observe the red traffic signal, understand it, and act on it. The pedestrian is also expected to understand and comply with the signals. POSs do not eliminate all risks for pedestrians when they must cross a busy road, but they do help them cross and they do reduce pedestrian crashes. A recent study (Appendix 2) showed that POSs reduce pedestrian crashes by 39%.

87. It is desirable to ensure that such devices are provided only where sufficient pedestrian demand exists, as drivers who use the route regularly will tend to ignore a device if they never see it used. Similarly, pedestrians tend to ignore or misuse a device if vehicle volumes are so low as to make its use unnecessary on most occasions. However, frequent random interruptions in a dense traffic stream may create congestion and increase the likelihood of vehicle collisions. These factors highlight the need for care in the setting and observance of pedestrian volume guidelines for each type of crossing facility. This manual does not offer any numerical minimum or maximum figures (warrants) to guide the selection of a crossing facility. Some national road authorities will have their warrants for this task. Instead, this manual encourages decision makers to look at the pedestrians' needs and to introduce the best facilities to serve those needs that the community can afford.

88. Spatial separation provides space (distance) between motor vehicles and pedestrians. Often, the first devices thought of in this category are overpasses and underpasses. These are essential in assisting pedestrians to cross expressways, but they should not be the first



Temporal separation devices. When activated, the signals change to red for drivers, giving pedestrians time to cross the road. Adequate pedestrian clearance time is vital.

option for other classes of roads. They are expensive, they take up space, and they are not always liked by all pedestrians. Also, to accommodate disabled pedestrians, these grade-separated facilities require special design features, such as long ramps, escalators, or lifts.

Pedestrian overpasses and underpasses are essential to assist pedestrians to cross expressways, but they should not automatically be considered to be the best pedestrian facility for other classes of roads.

89. Other devices within this category are more practical and potentially more useful for most “non-expressway” roads. For example, space can be provided for a pedestrian refuge in the middle of a wide road to give pedestrians their own area in which to move or stand. Pedestrians select a gap in the first lane(s) of traffic and cross to the refuge island, where they have space on which to stand while selecting a safe gap in the remaining lanes. Pedestrian refuges are shown to reduce pedestrian delays by 90%, pedestrian crashes by 50%, and fatal pedestrian crashes by 67% (Appendix 2). Pedestrian refuges are among the best, and most underused, pedestrian-friendly traffic devices. CAREC roads need more of them.

90. Other spatial separation devices are curb extensions, footpaths, and median strips. Details of these are provided in Chapter 6 of this manual covering civil works to assist pedestrians.



Spatial separation devices. Spatial separation devices include pedestrian underpasses, overpasses, curb extensions, and street narrowings.

Pedestrian refuges are among the best, and most underused, pedestrian-friendly traffic devices. CAREC roads need more of them.

D. Integration

91. The third element of the pedestrian strategy deals with drivers and pedestrians interacting or “sharing” the road with one another. They do this under the guidance of road rules that usually give “right-of-way” to motor vehicles. Pedestrians may

cross the road anywhere, but they will not have right-of-way over motor vehicles. According to national road rules, they must step aside and give way when a motor vehicle comes along. Therefore, with conflicts possible under this element, it is important for safety to manage vehicle speeds in local streets, in local areas, and on other streets used by many pedestrians.

92. An example of a safe integration device might be residential speed limits of 30 km/h on local streets while arterial roads are signed at 50 km/h. Lower speeds in residential areas help reduce the number of pedestrian collisions as well as the severity of those that do occur. Managing lower speeds can involve signs and police enforcement, or traffic calming, or both. Pedestrians on local streets can also be assisted with minor civil works, such as curb extensions and pedestrian refuges. These are most effective when applied with lower speed limits or traffic calming.



Integration. On busy roads with many pedestrians (such as outside markets), integration alone usually cannot offer desirable levels of safety unless vehicle speeds are managed in line with Safe System principles.

93. Within this third element of the pedestrian safety strategy, many pedestrian safety improvements can be implemented by road authorities or municipalities. Chapter 6 of this manual details civil works that can assist pedestrians, and Chapter 7 outlines the basic elements of traffic calming,

especially as applied in urban settings or in villages to help pedestrians. Deciding which one to use and coming up with the best design package (traffic calming, signs, civil works) are matters that require judgment and (importantly) empathy with the pedestrians.



Integration. Integration accepts that pedestrians and motor vehicles will mix, and it aims to ensure that this takes place under well-controlled and well-understood conditions.

V. Pedestrian Facilities

94. Only a limited number of pedestrian facilities are available to help pedestrians cross busy roads. Some of these facilities have variations (for example, there are pedestrian signals, POSs, PUFFIN crossings, and PELICAN crossings). These look similar but have small differences that can affect their operation and efficiency. Overall, engineers have a small number of facilities to choose from when faced with a need to help pedestrians cross a busy road. Selecting the best facility is an important task.

95. This chapter describes the pedestrian facilities most commonly available to help pedestrians cross busy roads and walk along roads. The decision about which facility to use at any location is not always straightforward. The budget available is usually limited. And some authorities make decisions based on volume warrants such as traffic volumes or pedestrian volumes. The use of volume warrants to decide on a pedestrian facility is no longer favored, as it can lead to situations where no facility is installed because a required pedestrian volume is not met, even though the pedestrians may be vulnerable (seniors) and traffic volumes or speeds may be high. Professional judgment, based on empathy with the needs of the pedestrians, is the best way forward.

96. All of the following facilities can assist pedestrians. Knowing which ones will offer the best assistance in a given situation, at the least capital cost and within the maintenance budget, requires skill and judgment.

A. Assisting pedestrians in crossing a road safely

97. Those responsible for deciding on the type of facility to install in a location where pedestrians need to cross a road safely usually consider the following:

- compliance with the policies of the road authority;
- compliance with national road rules and with national engineering standards;
- the status of the road within the road hierarchy;
- the number of pedestrians and motor vehicles;

- the four groups of “high-risk” pedestrians; and
- the financial resources available.

98. It is common practice to follow what was done in the past, applying similar treatments from one site to the next as resources permit. This is understandable, but it does not encourage innovation or the trial-testing of new facilities. When investigating pedestrian issues, engineers who put themselves in the shoes of the pedestrians will soon find that pedestrians need more, better, and sometimes “smarter” facilities. Finding the right balance of facilities for the mix of pedestrians at a location is a skill to be fostered. Engineers should try to be

- bold enough to consider new facilities that assist the pedestrians, even if those facilities may delay some vehicles;
- open-minded about the fact that some of the pedestrian facilities in current use (especially zebra crossings) do not serve their purpose well;
- prepared to devote resources to serving the biggest group of road users;
- open to monitoring and evaluating each new facility; and
- aware that one size does not fit all. Enhancements may have to be made in the location of the facilities in later years if monitoring shows the need for these.

99. Technology has allowed the development of new types of pedestrian facilities to assist pedestrians. These are useful facilities that better serve pedestrians and, in some cases, drivers too. Some are more costly than others. The real task is to decide which facility is the best one for the specified need and location.

100. First, there are regulatory facilities, where pedestrians have legal priority over motor vehicles but must rely on the compliance of drivers and other pedestrians for the facilities to work as they should. These regulatory facilities comprise the following:

- **Active** crossings, which display a red signal to the driver, who is then required by law to comply. These include pedestrian signals, POSs, PUFFIN crossings, and PELICAN crossings.

- **Passive** crossings, where the pedestrian on the crossing needs to be clearly visible to the driver for the latter to slow or stop and give way. In the CAREC region, the pedestrian (zebra) crossing is the only facility in this group of passive regulatory facilities. In some other countries, a part-time crossing that serves schoolchildren on their way to and from school is also in this group.

101. Second, there are facilities that do not give priority to pedestrians over motor vehicles but help them select gaps in traffic when they can safely cross the road. These facilities include minor civil works such as pedestrian refuges, curb extensions, traffic-calmed streets, and warning signs. Pedestrian overpasses and underpasses, of course, take away any need for such priority.

102. Dividing pedestrian facilities between these groups can help in deciding which facility is best for the location. The options given, when cross-matched with the agreed road hierarchy, can allow engineers to begin to focus on suitable facilities for the class of road. This approach helps build consistency across a network over time.

103. Table 7 shows the types of pedestrian facilities that may be suitable for use on certain classifications of roads. The table is not a perfect indicator for all

circumstances, but it gives a general summary of possible facilities and their appropriateness for the specified road classifications for engineers to consider. Individual road authorities may find it useful to modify this table to suit local conditions.

104. Tables like this are open to interpretation and amendment. This table should be reviewed and updated as experience with providing pedestrian facilities grows within the road authority. For situations that are not dealt with in this table, all options should be examined.

105. For example, overpasses and underpasses should not normally be needed on rural arterials, as pedestrian volumes on most of those roads are dispersed and low. But where a rural arterial road bypasses a village, and a school with substantial pedestrian demand is on the other side of the bypass from the village, grade separation may be an appropriate option, especially if the topography suits the purpose.

106. Passive crossings, generally not needed on local streets where traffic volumes and speeds are managed through traffic calming, may be necessary on some local streets that do not benefit from calming measures, especially in locations with substantial pedestrian volumes.

Table 7: Appropriateness of Pedestrian Facilities, by Road Classification

Road Classification	Pedestrian Facility				
	Overpass/ Underpass	Active Crossing (Signal)	Passive Crossing (Zebra)	Part-Time Passive Crossing	Advisory Facility, Including Civil Works
Expressways	Most appropriate	Inappropriate	Inappropriate	Inappropriate	Inappropriate
Urban arterials	May be appropriate	Appropriate	May be appropriate	May be appropriate	May be appropriate
Urban collectors	Inappropriate	Appropriate	Appropriate	Appropriate	Appropriate
Local streets	Should not be needed	Should not be needed	Should not be needed	Should not be needed	Appropriate
Rural arterials	May be appropriate	Inappropriate except in low-speed areas	Inappropriate except in low-speed areas	Inappropriate except in low-speed areas	May be appropriate
Other rural roads	Should not be needed	Should not be needed	Should not be needed	May be appropriate	May be appropriate

Note: Facilities are classed as “most appropriate” if they are considered most suitable for the given class of road (there are no alternatives); “appropriate” if they are deemed suitable; “may be appropriate” if, while suitable for the specified class of road, they do not present the only option (other facilities could also be considered); “inappropriate” if they should not be used on these roads; “inappropriate except in low-speed areas” if their suitability depends on keeping speeds on the roads below a defined level; and “should not be needed” if the location involves dispersed low pedestrian flows or a low-volume road, or both.

Source: Asian Development Bank.

107. Urban arterials are the class of road that is generally suited to all types of pedestrian facilities. They are also where most fatal pedestrian crashes occur. Urban arterials present the greatest challenges to engineers striving to help pedestrians without causing excessive traffic congestion.

108. A key message of this manual is, while describing each pedestrian crossing facility and assigning positives and negatives to each one is straightforward, deciding which crossing facility will best serve the road users poses a real challenge. Engineers, planners, and other decision makers should be open to new ideas and new ways of trying to help their pedestrian populations while not unreasonably disrupting other users of the road network.

For engineers to offer the best and most useful facilities to their pedestrian customers, they need to walk the site, day and night.

1. Design features for crossings

109. There are several important factors to be considered in designing pedestrian facilities for intersections and midblock locations (Table 8).

Table 8: Design Considerations for Crossings

Feature	Considerations
Crossing width	Should be at least 3 meters wide (or wider if pedestrian numbers so require). Narrow crossings can cause pedestrian congestion and may leave some pedestrians on the road when the signals change.
Crossing length	Should be the shortest crossing that is practicable (to benefit the elderly or infirm and to minimize delay to vehicles). Curb extensions can reduce the crossing length, or a pedestrian refuge can be provided to allow crossing in stages.
Crossing orientation	Crossings should be at right angles (or as close as practical) to the road to help vision-impaired pedestrians cross the road within the marked crosswalk. Vision-impaired people obtain cues from the orientation of the curb ramps. Directional guidance (tactile tiles and audio-tactile devices) is desirable.
Surface	Changes in a footpath's surface, particularly at crossings, must be easily detectable (especially to vision-impaired pedestrians). Surfaces must be maintained in good condition to avoid tripping or slipping risk.
Sight distance	Crossing facilities should be located <ul style="list-style-type: none"> • where there is a clear view between approaching motorists and pedestrians on the crossing or waiting to cross; and • not immediately beyond crests or on horizontal curves. Motorists must have sufficient sight distance (approach sight distance) after noticing the crossing to be able to react to any pedestrians on the crossing, or about to step onto it, and stop their vehicles before reaching that point.
Stop-line location	Stop lines are essential at crossings controlled by traffic signals. They help minimize the encroachment of vehicles, which <ul style="list-style-type: none"> • is a direct hazard to pedestrians; • can be a physical barrier to pedestrian movements; and • obstructs the line of sight between adjacent stopped vehicles and pedestrians already on the crossing.
Access to roadway crossings	Curb ramps are needed to help pedestrians move between the footpath and the roadway. Curbs are a barrier to many people. Those in wheelchairs cannot mount a curb if it is too steep. These ramps should be provided at midblock crossings, at all intersections, and at other places where access to and from a footpath is needed.

Source: AUSTROADS (2017a).

B. Spatial (distance) separation facilities

110. Spatial separation facilities provide space (distance) between motor vehicles and pedestrians. Facilities in this category include pedestrian overpasses, underpasses, pedestrian refuges, curb extensions, footpaths, and medians. These facilities do not give priority to pedestrians but allow space on which pedestrians can stand while choosing safe gaps in traffic. Overpasses and underpasses are discussed below. The other facilities are described in Chapter 6 (Civil Works to Assist Pedestrians).

1. Pedestrian overpasses (footbridges)

111. An overpass (or an underpass) is often proposed during the design of large road projects in the CAREC network, to help pedestrians (at a school or in a village) cross the new road. In some locations, this is a good decision. But in others, the well-intentioned desire to facilitate pedestrian movement can lead to a wasted investment, as the pedestrians simply prefer to cross at road level. Contrary to what decision makers believe, overpasses are not a panacea for all pedestrian problems. Knowing where and when to install a pedestrian overpass because it is “the most appropriate treatment” for the location is a sensitive matter that calls for clarity, logic, and experience.

112. Pedestrian overpasses (and underpasses) may be appropriate where

- road access is restricted (as on expressways and motorways);
- speeds or traffic volumes are high, there is considerable pedestrian delay, and pedestrian demand is focused on a specific point (not dispersed);
- pedestrian crashes are a serious problem, and the previous point applies; or
- nearby commercial buildings generate large pedestrian volumes that can be served by grade separation between one building and its neighbor on the other side of the road at the same level.

113. Pedestrian overpasses (and underpasses) are usually *not* appropriate in locations where

- traffic speeds or volumes are not high enough to cause substantial pedestrian delays;

- pedestrian crossing demand is dispersed over a considerable length of road;
- pedestrians perceive the crossing time or distance to be much less at road level than through an overpass or underpass;
- there is a central median that can help pedestrians cross in stages (medians offer useful spatial separation);
- numbers of disabled pedestrians cannot be accommodated by an overpass or underpass (because of a lack of suitable ramps, elevators, and escalators);
- the facility cannot be well maintained and kept clean and inviting (particularly in rural locations, and especially in the case of underpasses); or
- pedestrians have reasons to fear for their safety.

114. For various reasons, many pedestrian overpasses and underpasses are greatly underused. Although these grade-separated facilities eliminate conflicts between vehicles and the pedestrians who use the facility, they do increase walking distance because of the requirement to change levels or make detours.

115. A research study in the United States (US) (Zegeer 1998) has shown that 95% of pedestrians will use grade-separated facilities if there is no increase in travel time compared with walking across the road at grade; almost nobody will use the facilities if it will mean 50% more travel time or longer.

116. Pedestrians do prefer to cross a road by the shortest path, which is invariably straight across. They cannot be expected to walk far to get to an overpass or underpass. The decisions they make in the process may reflect their view of the volume and speed of the traffic, the likelihood of finding useful gaps in traffic, their own gap acceptance skills, and their ability to run if necessary. In some cases, the decision also takes into account a conclusion reached about whether using the overpass will leave enough time to catch their bus. Pedestrians are human beings and they are imperfect decision makers, but they usually know what they like and what they do not. They will vote with their feet, and that is why so many of them will cross at road level even if they must negotiate traffic.



Overpasses. Overpasses vary from basic structures to architecturally superb facilities. The better ones have ramps, escalators, or elevators to improve access for people with disabilities. The location of the overpass and user perceptions of the time spent in using it are important determinants of its eventual use.

117. This situation can prompt the road authority to use a variety of barricades or fences, to block the pedestrians' route and direct them to the overpass or underpass. But even this tactic often fails, as some pedestrians walk to the median, hoping to find a way across, and end up walking along the road. Some young adults jump the fence, others cut holes in the fence, and sometimes a vehicle smashes through the fence, causing a break that can take time to repair. Pedestrians stepping onto the road through a break in the fence are not easily seen by drivers and are thus at increased risk. So, in the worst situations, the pedestrian overpass stays underused while the barricade fencing below is breached and crossing pedestrians have their sight lines restricted.

118. This manual conveys a clear message: build pedestrian overpasses only in locations that are deemed appropriate (see para. 110). These are over expressways, or where high pedestrian volumes and high-speed traffic intersect at a well-defined point. If a location does not meet these criteria, other proven facilities can serve pedestrians and motorists well. The skill lies in selecting the facility that will best serve the pedestrians at that location. More pedestrian facilities are detailed in the rest of this chapter.

119. Design considerations for pedestrian overpasses include the following:

- vertical clearance for the vehicles below (often a 4.6 m minimum clearance, but some countries require more);
- suitable treads and risers on the stairs for comfortable use (up and down);

- antislip stairs, together with good handrails to minimize slips;
- a cover to protect users from rain, snow, and sun;
- ramps (typically with 5% grades and landings every 15 m) for wheeled and mobility-impaired pedestrians, bicyclists, and others;
- elevators (while desirable, these may be justifiable only in city centers where volumes are high, and good maintenance can keep them in good working order);
- piers that do not restrict or hinder pedestrian movement on the footpath below;
- piers that are not roadside hazards for motor-vehicle traffic. Refer to Manual 3 (Roadside Hazard Management) in this series of CAREC manuals for more information on this;
- all-weather paths leading to and from the overpass in each direction;
- a well-lighted pedestrian path on the stairs, ramps, and the overpass itself; and
- screens on the overpass to prevent objects from being thrown or dropped from the bridge.

For overpasses and underpasses to operate effectively and safely they must attract the pedestrians to cross. To do this, they must be a more appealing option to the users than crossing at road level.

2. Pedestrian underpasses (subways)

120. Most issues relevant to pedestrian overpasses also apply to pedestrian underpasses, but there is a small difference in pedestrian preference for one over the other. Underpasses are less well used because of the perception that their use can compromise personal safety. Women and the elderly are often reluctant to use an underpass unless they get an unobstructed view of the entire facility before entering, or unless it offers attractions (such as shops) that attract a steady number of pedestrians. To allow a clear view through the underpass, and for maximum effectiveness, approach footpaths should lead into the

facility in a way that requires pedestrians to go out of their way to avoid using it. In addition, the underpass should be well-lit, and used by many people at all hours. Underpasses have the advantage of providing shelter from the weather, but some may be prone to flooding.

121. Design considerations for pedestrian underpasses (subways) include the following:

- suitably wide and open;
- a central location, amply served by approach footpaths, such that pedestrians must go out of their way to avoid using the underpass;
- all-weather paths leading to and from the underpass in each direction;
- suitable antislip stairs, for comfortable use up and down;
- handrails to assist those who need support;
- a cover over the steps and footway to protect users from the rain, snow, and sun;
- adequate drainage at footpath level to prevent flooding;
- ramps (typically with 1:14 grades), escalators, or elevators (while desirable for wheeled pedestrians, these facilities are usually justifiable only in city centers where volumes are high, and regular maintenance can keep them in good working order);
- good streetlighting and excellent internal lighting;
- walls or structures on the footpath to prevent other pedestrians from falling into the subway, while not restricting the movement of pedestrians on the footpath, or presenting roadside hazards for motor-vehicle traffic;
- shops where feasible in urban areas; and
- doors and heating in extreme climates.

C. Active and passive temporal (time) separation pedestrian facilities

122. Temporal (time) separation is the element of the pedestrian safety strategy that separates pedestrians from motor vehicles in time. Temporal separation facilities are regulatory devices that are supported by national road rules. Because of this, they must comply with national standards for their appearance as well as their operation. Standardized colors and symbols, signal placement, and operating times and durations are important to enable users (pedestrians and drivers) to see, react, and respond to them quickly.



Underpasses. Underpasses are often designed with architectural objectives, rather than road safety and personal safety, in mind. The location of the underpass and the orientation of the approaches are important determinants of its eventual use. The best underpasses provide for the disabled, have good lighting, and offer an open, welcoming feel to users.

123. There are two groups of regulatory facilities: a family of active facilities (pedestrian signals, POSs, PUFFIN crossings, and PELICAN crossings) and one passive facility (the pedestrian, or zebra, crossing).

124. Active facilities require the driver to comply with a red signal, regardless of whether the crossing has any pedestrians. The driver is required by law to stop at the red signal and remain stationary until the signal turns green. The passive facility, on the other hand, requires the driver to see the pedestrian entering or on the crossing and give way to him or her.

125. Why does this matter? It matters because national road rules require drivers to discern signals at active crossings, and pedestrians on passive crossings. Engineers must take note of this fine difference and ensure that the signals are very conspicuous in one case, and that there are clear sight lines to and from the pedestrian in the other. Civil works, such as curb extensions or pedestrian refuges, may be used at both active and passive facilities to enhance sight lines. At both facilities, regulatory or warning signs and regulatory crosswalk markings are required, while good lighting, curb ramps, and good footpaths are certainly desirable. Indeed, for the construction of any pedestrian facility, a package of additional civil works will normally be added to the collection of signals, signs, and markings.

D. Active pedestrian crossing facilities

1. Intersections: General

126. Intersections are important parts of a road network for all groups of road users because they are places where changes of direction can take place. For pedestrians, these are often the places where they must cross a road, whether they want to or not. If they turn one way at a cross road intersection, they may stay on the footpath, but if they turn the other way or continue ahead, they must cross at least one road. For this reason, it is desirable that all intersections, especially in urban areas, be provided with facilities on each corner to assist pedestrians (including disabled pedestrians) in crossing safely and conveniently.

127. Chapter 6 of this manual gives details of the most common minor civil works that assist pedestrians. But to start with, here is a useful list of fundamental design considerations for pedestrians at any intersection:

- wide and skid-resistant footpaths, to suit the pedestrians' "desire line" (the route where pedestrians wish to go);
- footpaths with no steps or stairs (impediments for impaired pedestrians);
- paths kept free of obstructions (poles, trees) around the intersection;
- curb ramps on each corner;
- drainage pits kept separate from pedestrian paths and curb ramps;
- crossings aligned on a straight path;
- generous setbacks between traffic lanes and footpaths (where practicable);
- clear, open sight lines between pedestrians and motorists;
- small radii corners (3–4 m) where practical, to manage the speed of turning vehicles; and
- physical "splitter" islands, at least in the side streets, to promote lane discipline and prevent turning vehicles from cutting corners.

128. These basic design features are highly desirable for any intersection, signalized or non-signalized. To help pedestrians at signalized intersections, there are additional issues to be considered (see the next section).

2. Intersection signals

129. Intersection signals are essential tools used to manage traffic in busy urban areas. They provide temporal separation between motor vehicles and they keep pedestrians and traffic apart on road crossings, although turning vehicles may still present a risk. Traffic signals are important tools that can be used to implement road-user priorities within a network operation plan. Various traffic signal techniques can be applied to support the following:

- general traffic priority;
- public transport priority;
- freight priority;
- bicycle priority; and
- pedestrian priority.

130. For road authorities with coordinated traffic signal networks, there are a variety of safety initiatives that can support priority for these user groups. Some of the common initiatives that give pedestrian priority within a coordinated signal network with variable signal timings are given in Appendix A at the end of this manual. The list of references also contains several good sources of information on this topic.

131. A dynamic, vehicle-activated network of coordinated traffic signals is a highly desirable facility for a road authority to have. Advanced traffic signal coordination allows signals to respond to different demands as and when required. These systems provide efficiency for all road users, and they minimize lost time when volumes are low or nonexistent. However, as most traffic signals across the CAREC operate under fixed time plans, this manual offers ideas and suggestions that can help pedestrian safety and convenience at fixed-time traffic signals.

132. Pedestrians are normally grouped with vehicle movements to form a phase. This grouping usually has the pedestrian movement running concurrently with parallel vehicle movements (Figure 7). Where turning vehicles can cross a pedestrian movement, it may be necessary to provide pedestrian protection. The degree of protection can vary, but general approaches include full protection for the duration of the pedestrian movement or protection only for the initial stages of the pedestrian movement.

Figure 7: Simple Two-Phase Signal Diagram Showing Pedestrians (Dashed Lines) Walking in Parallel with Traffic

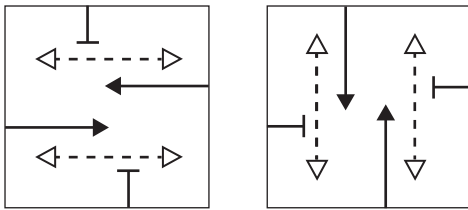

Source: Asian Development Bank.

133. The risk of serious pedestrian crashes at signalized intersections tends to be higher if

- the intersection is large;
- left-turn movements (right turns in Pakistan) are not fully controlled (or banned); or
- the angle of skew of the intersection is more than 5 degrees from the perpendicular.

134. To lessen these risks, there are initiatives that can be undertaken as a total package. The size of an intersection may be reduced through physical

channelization, including the use of curb extensions, splitter islands, and sheltered turn islands. Thermoplastic line markings are an important part of signalized intersections, and are even more valuable at large intersections. Good line marking shows drivers where to stop, guides pedestrians where to walk, and assists drivers as they make their large-radius turn (a left turn in most CAREC countries, a right turn in Pakistan). Stop lines, pedestrian crosswalks or zebra markings, and turning lines are valuable additions to a signalized intersection.

135. Where turning traffic presents a risk to pedestrians, full turn control of the traffic (Figure 8) is the common way of reducing that risk. Full (or at least partial) protection for pedestrians should be provided whenever pedestrians are placed at high risk, such as when

- the sight line to the crossing is restricted;
- the speed of the turning traffic is high; or
- there are two lanes (or more) of vehicles turning left (right in Pakistan) through the pedestrian movement, and those turning vehicles are opposed by oncoming traffic.

Figure 8: Fully Controlled Left Turn

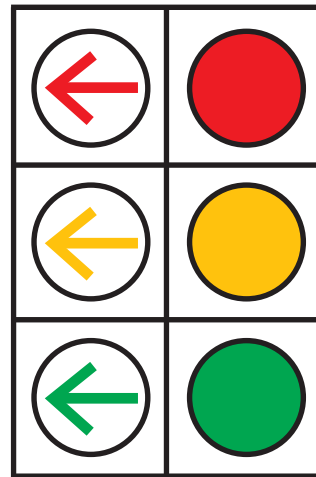

Note: Fully controlled left turns can give priority to parallel pedestrian movements, as well as reducing the risks of left turn against collisions.

Source: Asian Development Bank.

136. Other things be done throughout CAREC countries to assist pedestrians at signalized crossings. By placing themselves in the pedestrians' shoes,

engineers will quickly find a range of options for use at signalized intersections to improve pedestrian safety and convenience, such as the following:

- clear, conspicuous pedestrian signals (Walk, Don't Walk);
- adequate clearance times;
- good line markings;
- pedestrian push buttons, for pedestrians to call up their Walk interval (if the signal system permits);
- pedestrian push buttons that are accessible to all, including those in wheelchairs;
- curb ramps on all corners; and
- small-scale civil works (curb extensions, streetlights, splitter islands, paved footpaths), to promote accessibility.

Good maintenance of signalized intersections (indeed *all* pedestrian facilities) is essential for community safety.

a. Pedestrian interval

137. At most signalized intersections, pedestrian movements run concurrently with parallel vehicle movements, or they may run in an exclusive pedestrian phase. At many signalized intersections, the pedestrian interval comes on automatically with

the traffic phase. No pedestrian push buttons are required, and this process can work well in busy city centers, where demand from pedestrians is constant. It also works well at smaller intersections, where pedestrians do not have a long crossing distance.

138. However, if the road to be crossed is wide, the pedestrian time can become the longest (dominant) interval in the signal cycle. On roads divided by a wide median, the pedestrian interval is often split into two parts, causing the pedestrians to wait on the median for their next interval. This delay can frustrate some pedestrians and cause them to cross against their signal. A long interval can lead to excessive cycle times and, in turn, to driver abuse of the signals, especially if no pedestrians are waiting to cross (perhaps late at night).

139. For these reasons, pedestrian intervals are introduced through push-button detection when the signal system can accommodate this. For parallel crossings at fixed-time-signal intersections, pedestrian demand has to be received before the relevant phase starts. Pedestrian intervals can also be introduced automatically (that is, every signal cycle) in areas where there is heavy and consistent pedestrian movement.

140. The pedestrian phase, and its relationship with the parallel vehicle phase at signalized intersections, is shown in Figure 9. There are normally three pedestrian signal displays: Walk, flashing Don't Walk, and steady Don't Walk. The flashing Don't Walk display corresponds to clearance intervals 1 and 2 in the figure. Note the overlap between clearance interval 2 and part of the vehicle clearance interval (the intergreen).



Signalized intersections. Signalized intersections across the CAREC road network vary greatly in the level of safety and amenity provided to pedestrians. Too many have insufficient clearance times, leaving some pedestrians caught in traffic (photo credit [left photo], Ministry of Transport, Tajikistan).

Figure 9: Pedestrian Movement Intervals

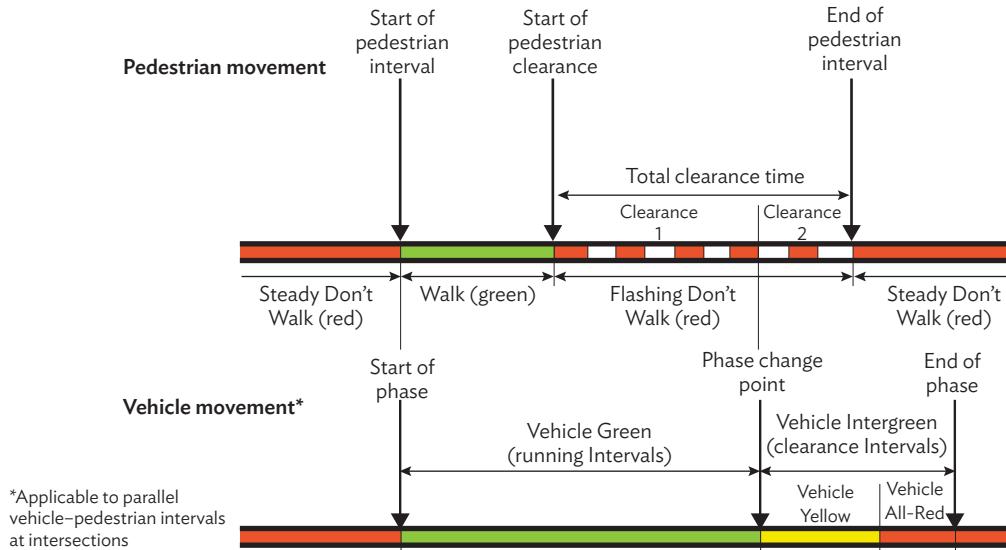

Source: AUSTROADS (2020), page 214.

b. Pedestrian clearance times

141. The pedestrian clearance time is the most important part of the signal cycle for pedestrian safety and comfort. Pedestrians who began crossing during the Walk signal are given time to complete their crossing safely. It comprises clearance time 1 and clearance time 2, as can be seen in Figure 9.

142. It is a common misconception that people must get all the way across a road while the Walk signal is displayed. This is not true. The purpose of the Walk signal is to let pedestrians know when they may start to cross the road. This interval is followed by a flashing Don't Walk signal, which tells pedestrians not to start crossing. During this time, those pedestrians who began their crossing during the Walk signal will have enough time to finish their crossing safely (provided the signal designers designed the clearance time correctly). But clearance times are often too short to be effective and some pedestrians can be left on the crossing as conflicting vehicles start to move. Too many pedestrians cross CAREC roads with a long Walk signal and a noticeably short clearance time. They are enticed onto the crossing with long walk periods, but some get caught on the

road when the traffic starts up. This is a major failing of many CAREC signals, but one that can be readily addressed at almost no cost.

143. At all types of pedestrian signals, it is necessary to let the pedestrians know when they may start their crossing, when they should not start their crossing, and when they should be clear of the crossing because the motor traffic is about to start. Adequate length clearance times are vital for safety. For motor traffic, three aspect signals are used for this: a green signal means "pass through," yellow means "stop but proceed through if too close to the junction," and red means "stop and do not enter the intersection." These three aspect signals are not often used for pedestrians; instead, reliance is placed on a green Walk, a steady red Don't Walk, and a flashing Don't Walk clearance signal, which is the equivalent of the yellow interval for traffic. In some countries, a flashing green Walk signal is used instead of the flashing Don't Walk for the pedestrian clearance time. There is no known advantage to be gained from flashing the green pedestrian signal versus the red, but all displays should be consistent within a country, and preferably across the region.

144. But while the yellow time for road traffic is usually a standard time (commonly, 3 seconds, depending on road width), the clearance time for pedestrians seems to vary greatly. There is an urgent need to provide adequate, consistent clearance times for pedestrians. This is missing from many CAREC signals at present. The following formula can be used to calculate a pedestrian clearance time (in seconds):

$$T_{pc} = lc/vpc$$

where

T_{pc} = total pedestrian clearance time (in seconds)

lc = crossing distance (maximum distance to be cleared)

vpc = pedestrian walking speed (in meters per second) (1.2 m/sec is commonly used)

145. The flashing clearance time should be calculated on the width of the road divided by a standard walking speed. A speed of 1.2 m/sec is commonly used for clearance times. This is about the fifth-percentile walking speed observed during clearance times. Because this is a clearance time, the designers must assume some pedestrians may not have begun to cross at the start of the Walk signal but instead may have stepped onto the crosswalk just before the clearance signal was turned on. The road rules permit pedestrians to do this, and that is what the Walk time is for. These late starters may not be far onto the crossing when the Walk signal ends and the clearance signal begins. These pedestrians rely on the clearance time, not the Walk time, to allow them to clear the road, and that is why this part of the pedestrian interval is the most critical for pedestrian comfort and safety.

Adequate pedestrian clearance times are vital for safety.

146. For a four-lane road that is 15 m wide and with a clearance walking speed of 1.2 m/sec, designers must allow 12.5 seconds of clearance time. After this, there may be a further 3 seconds of all-red time, when the Don't Walk signal and the red signal for traffic are both displayed. Longer clearance times will be needed for wider crossings, but if the same walking speed is consistently used, road users will soon recognize the network consistency and, in turn, will learn to trust the signals.

147. Road authorities across CAREC are urged to review their signal phases and to seek pedestrian clearance times that are determined from a consistent walking speed (1.2 m/sec is suggested). Consistency leads to trust from the users, which is a critical factor for road safety. Consistent application of pedestrian timings, along with many other features—consistently correct signs, consistently well-maintained line marking, and consistently good signals—all build up trust and confidence between the users and the road authorities.

c. Pedestrian countdown timers

148. Pedestrian countdown timers can help create a more pedestrian-friendly environment by giving pedestrians more information about the time they must wait, and the time left to cross the road. They let pedestrians know how many seconds they have left to cross the road before the steady Don't Walk signal is displayed. This can make them more aware of their ability to cross the road and may enable them to make better decisions when crossing the road.

149. However, some pedestrians use the countdown timers to decide whether to dash across the road or not. Rash behavior can increase, and it may be for this reason that the safety value of countdown timers is open to debate.

150. Countdown timers can operate during any of the three pedestrian displays:

- during the Walk display;
- during the clearance display; or
- during the steady red display until the next Walk display.

151. Counting down the clearance time is the most useful and practical of these. It encourages pedestrians to move briskly across the remaining part of the road before any conflicting vehicles get a green signal. Counting down the steady red display is not recommended, as confused pedestrians may relate this to the clearance time rather than the waiting time. Besides, counting this time is impractical if there is any sort of vehicle actuation in the signal timing. The signals need to operate strictly fixed-time for the countdown of the steady red signal to work. Counting down the Walk time is optional.

152. Technology has made available a yellow countdown timer to display the clearance time, replacing the flashing Don't Walk signal. The three-



Countdown timers. Pedestrians like countdown timers. But these timers need sufficiently long clearance times; otherwise, they can still lead to some pedestrians being stranded in traffic. All timers should be consistent (in appearance, color, timing, and operation) across a city.

color option does match the signals for motor traffic. Note that the clearance time is still equally important, whether a flashing Don't Walk signal or a countdown timer is used. Pedestrians need a fair and reasonable clearance time at all signalized crossings. For visually or hearing-impaired pedestrians, audio-tactile facilities can operate as usual at crossings with countdown timers.

d. Right turns on red

153. Many traffic engineers seek to maximize the capacity of urban intersections by allowing right turns (left turns in Pakistan) to be made against a red signal. This can be done in several ways:

- by changing the road rules to allow right turns against a red signal anywhere, and at any time (without signs);
- by changing the road rules to allow right turns against a red signal anywhere, and at any time, except where a sign prohibiting right turns against red signals is displayed (sign-prohibitive); or
- by changing the road rules to allow a sign to be placed at intersections where it is allowed (sign-permissive).

154. Although they have been used in some countries for many years, right turns on red (RTOR) are controversial because they place the motorist's time above the safety of pedestrians. The small number of studies about the safety performance of RTORs all show that pedestrians experience a substantial increase in crashes because of the rule.

- A US National Highway Traffic Safety Administration report noted a 14% increase in collisions due to RTORs, adding that "the majority of RTOR crashes involve a driver looking left for a gap in traffic and striking a pedestrian (or bicyclist) coming from the driver's right."
- A US Department of Transportation study found that the adoption of RTOR led to increases in pedestrian collisions of between 43% and 107% (at various intersections in several states and cities).
- Two other similar studies showed increases in pedestrian crashes due to the introduction of RTOR by 44% and 60% (Wikipedia Turn on red).

RTOR presents a serious safety problem for pedestrians; safer options to improve traffic capacity are available.

155. With such figures demonstrating a serious safety problem, decision makers should review the practice in their country. RTORs impose a cost through pedestrian collisions. Therefore, it is desirable for road safety engineers to examine their network closely and to consider options such as the following:

- prohibiting RTORs outright;
- banning RTORs where volumes of pedestrians and conflicting vehicles are high;

- installing green right-turn arrows to control turning movements and to be activated only when the opposing pedestrian phase *is not called*;
- installing a red right-turn arrow to control turns at the signals and to be activated when the opposing pedestrian phase *is called*; or
- channelizing the intersection by constructing a right-turn slip lane that permits vehicles to turn right before the traffic signals. Pedestrians who cross the slip lane have the right-of-way (with signals or a zebra crossing).

3. Midblock pedestrian signals

156. There are two types of midblock pedestrian signals: those belonging to the first are simply called pedestrian signals, and those of the second type are called pedestrian-operated signals (POSSs). The key difference between these two types is that POSSs have a push button for pedestrians to push to register their intent to cross the road. Pushing this button tells the signal controller to call up the pedestrian interval.

157. Both types of crossings have vertical red–yellow–green signal displays facing the motorists (although some may be horizontal). These may have light-emitting diode (LED) displays or halogen globes or some other form of illuminating technology, but the message they give should be consistent with that conveyed by other traffic signals in the city or region so that motorists readily recognize and obey them.

158. In both types of crossings, there are two aspect signals indicating “Walk” (a green pedestrian figure) and “Don’t Walk” (a red pedestrian figure) facing the pedestrians across the street. When the Walk (or green man) is showing, pedestrians may begin to cross the road. This is followed by a flashing Don’t Walk clearance time. The clearance time is most important for pedestrian safety, but it is often overlooked in signal timings on CAREC roads. The importance of the clearance time and the process of creating a safe clearance time were detailed in section D.2.b. of this manual.

159. Pedestrian signals do not have pedestrian push (or activation) buttons. They are fixed-time devices, meaning that the signals operate on a fixed timing plan, which remains consistent during agreed hours on agreed days. Several plans may be used in a day (AM peak, midday, PM peak, nighttime), and there may be other plans for weekends. Such fixed-time signals are relatively simple, and they cannot adapt to sudden changes in traffic demand. But they can serve

Figure 10: Layout for a Set of Midblock Pedestrian Signals across a Divided Multilane Road

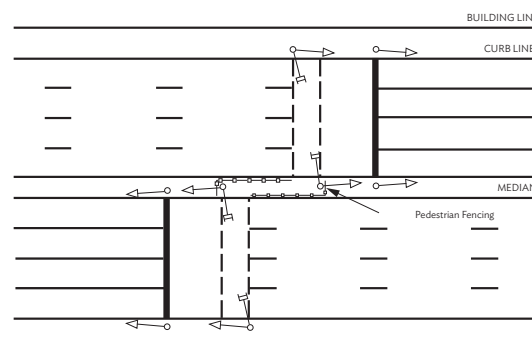

Source: AUSTRROADS (2017a), page 57.

pedestrians well, provided that the signal cycles are short enough to minimize pedestrian waiting time.

160. A key element of urban road safety is consistency in providing traffic signals that are obeyed by all road users. The police have an important role in this task, but engineers need to help them and the pedestrians by providing consistently good-quality signals that serve the needs of the users.

161. It is therefore important to time the signal phasing, both to discourage illegal crossings by pedestrians and to reinforce the need for all drivers to stop on the red signal. Long cycle times for pedestrian signals (more than about 75 seconds) can cause impatient pedestrians to ignore the signals and cross against the Don’t Walk signal. But while fixed-time pedestrian signals may have quite short cycle times (for high volumes of pedestrians), these can become ineffective, and even dangerous, late at night when pedestrian numbers drop. If a red signal shows to drivers, but no pedestrians are there to cross, it is a common but illegal and high-risk activity for drivers to ignore the signals and drive through. If such practices become endemic within a city, the risk of serious pedestrian–vehicle collisions, especially late at night, increases.

162. Pedestrian signals serve pedestrians better when installed with a combination of civil works such as curb extensions, curb ramps, paved footpaths, and streetlights.



Pedestrian signals. The essential components of pedestrian signals are conspicuous signal displays (for the drivers and for the pedestrians), clear line markings (to define the crossing area), easy pedestrian access (via curb ramps), and overhead lighting. Adequate pedestrian clearance time is vital for safety. The addition of pedestrian push buttons (creating POSs) offers a better level of service to the users.

4. Pedestrian-operated signals (POSs)

163. POSs are signals with push buttons that pedestrians press to record their intention to cross. They create gaps in traffic to give pedestrians time to cross the road. Like most other traffic control items, POSs require good driver and pedestrian compliance, but they serve a useful purpose and are appreciated by pedestrians. And having push-button activation means the signals remain green to the motor vehicles until a pedestrian call is recorded; this diminishes the time lost to drivers and, in turn, improves their compliance. POSs have a crash reduction factor (CRF) of 25%, compared with having no crossing (Appendix 2).

Pedestrian-operated signals (with audio-tactile facilities) are excellent for arterial roads.

164. POSs can operate in fixed-time or vehicle-activated automatic traffic control systems. They look the same as pedestrian signals (section D.3.) to pedestrians and to drivers. Facing the drivers are traffic signals (red–yellow–green), and across the street are two aspect signals that indicate Walk (a green pedestrian figure) or Don't Walk (a red pedestrian figure) for the pedestrians. A green signal is displayed to motorists until the time a pedestrian presses a button to activate the signal sequence. The pedestrian may have to wait a few seconds for the Walk signal to appear, depending on the time the button was pressed within the overall cycle for the signals.

165. When pedestrian demand is light, there will be fewer cycles per hour than in peak pedestrian times. But in peak pedestrian times, and especially if these coincide with peak traffic times, a limit can be placed on the frequency that the pedestrian phase is called up to avoid traffic congestion. The ability to balance these two demands will be governed by the technology within the traffic signal controller as well as any network coordination.



Pedestrian push buttons. There are many types of pedestrian push buttons. Some are easier to use, or have more features, than others. Details of the key features of push buttons are given in sections D.7 and D.8.

166. Besides making the signals clear and conspicuous to all and placing the push buttons within range of the pedestrians (including those in wheelchairs), it is necessary to also help the pedestrians get on or off the crossing. Curb extensions, curb ramps, and pedestrian refuges are useful options. Good streetlighting aids safety at night.

167. There are some issues to consider when designing the push buttons—such as a call record indicator, and a vandal-proof button that can be used by the mobility-impaired as well as all others. Audio-tactile facilities inside the detector buttons are desirable for visually impaired and deaf pedestrians. Details of call buttons are given in sections D.7 and D.8.

5. Pedestrian light control (PELICAN) crossings

168. The PELICAN crossing is a variation of the POS. The hardware looks like POS hardware to drivers and pedestrians, but the signal operates a little differently, because the PELICAN crossing incorporates a flashing yellow display for motor-vehicle drivers (Figure 11).

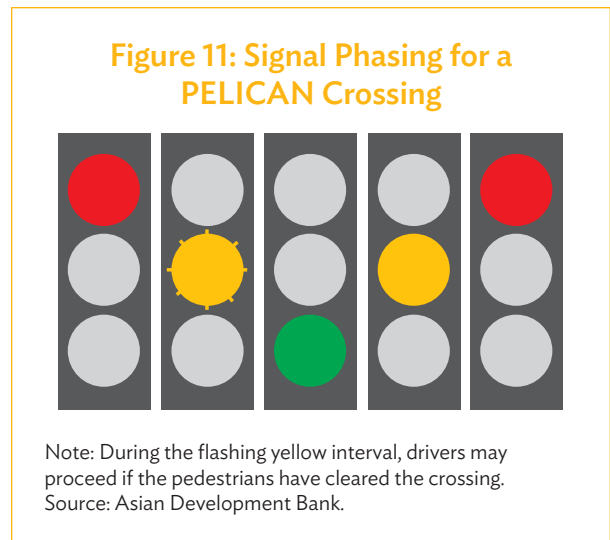

169. A few seconds after the pedestrian Walk ends, and during the pedestrian clearance time, the yellow signal flashes to drivers for a preset time (8–10 seconds). During this time, drivers may proceed, provided

they give way to any pedestrians who are still completing their crossing. Experience shows that most pedestrians will have cleared the road by this time, but for those who are slow, or who enter late during the Walk time, the flashing yellow signal gives them regulatory right-of-way on the crossing. Drivers must give way to them and allow them to finish crossing.

170. PELICANS are a useful type of crossing, giving assistance to pedestrians (with time separation) and drivers because they reduce driver delays overall. Studies show a 40% reduction in vehicle delay with a PELICAN crossing compared with a POS, while the safety performance of each type of crossing remains similar. The cost of the software for converting a POS to a PELICAN is quite low. A decision to introduce a PELICAN crossing should usually involve a reduction in vehicle delays versus driver expectancy. But some drivers, confused by the flashing yellow display when they see it for the first time, may think the signals have gone into fault mode. A widespread public awareness campaign should be considered if a PELICAN crossing is proposed, and national road rules should be checked, as they may need to be updated when PELICAN crossings are introduced.

6. Pedestrian user-friendly intelligent (PUFFIN) crossings

171. Developed in the United Kingdom, and now used in several countries around the world, PUFFIN crossings are the most advanced type of crossing available at present. PUFFIN crossings use overhead detectors (like the detectors that open supermarket doors for approaching customers) pointing onto the crossing from each side. The crossings look and operate like POSs except that the small detector above the pedestal monitors the progress of pedestrians on the crossing, allowing the clearance time to be reduced when all pedestrians have crossed quickly, or extended for slow-moving pedestrians.

172. At a PUFFIN crossing, a pedestrian pushes the detector button and waits for the green Walk signal to appear. The pedestrian then crosses when the Walk signal is displayed. Traffic signal design practice usually gives a Walk signal duration of 6–10 seconds, depending on the pedestrian volume. The nominal pedestrian clearance time is based on a walking speed of 1.2 m/sec but is variable. If the crossing is quickly clear of pedestrians, the detector recognizes this, shortens the clearance time, and directs the signals to open again to traffic. This situation occurs quite often,

usually when there are few pedestrians and all cross quickly.

173. When a very slow pedestrian (elderly, disabled, injured, or possibly intoxicated) is still on the crossing at the end of the normal clearance time, the overhead detectors recognize this and increase the clearance time up to a preset maximum period designed to avoid pedestrian abuse and to prevent traffic congestion. In these situations, slow pedestrians receive added time to clear the crossing, helping them feel safer and more confident in their crossings. Slow pedestrians crossing roads are surprisingly few. Studies of new PUFFIN crossings when they were first introduced in Australia showed a 40% reduction in average driver delay at these crossings compared with conventional POSs. They also showed a 26% reduction in crashes. PUFFIN crossings therefore benefit slow pedestrians as well as vehicle users. In short, PUFFIN crossings are win-win facilities.



Detector for slow moving pedestrians. PUFFIN crossings feature a small overhead detector atop the pedestal. This small detector looks for pedestrians on the crossing. If the detector finds that all pedestrians have completed their crossing, it prompts the signal controller to open the green signal to traffic.

If a slow-moving pedestrian is detected at the end of the normal clearance interval, the clearance is extended up to an agreed maximum. The red signal for motorists is retained during this time, and the slow-moving pedestrian is given more time to clear the crossing.

PUFFIN crossings show a 40% reduction in average delay to drivers (compared with conventional push-button pedestrian-operated signals), while assisting slow pedestrians. More PUFFIN crossings are needed on the arterial roads of CAREC cities.

The PUFFIN crossing is the most useful pedestrian facility available.

174. PUFFIN crossings have many advantages over traditional POSs. They

- look the same as pedestrian-operated signals;
- are used by pedestrians and drivers in the same way as conventional POSs;
- reduce vehicle delays by 40%;
- assist mobility-impaired, elderly, wheeled, and other slow-moving pedestrians;
- have a proven 26% crash reduction factor for pedestrian crashes (Appendix 2); and
- involve a relatively low additional cost compared with conventional POSs.

175. Some versions of the PUFFIN crossing also have curbside detectors to cancel a pedestrian call when the pedestrian moves away after pressing the button to activate the signal. Some pedestrians, for example, change their mind and go elsewhere instead of waiting for the Walk signal. Some shuffle around or turn to look in at a shop window while waiting to hear the signal beeper. If the overhead curbside detector can no longer detect the pedestrian within the small designated area, it assumes the latter no longer wishes to use the crossing and it cancels the call to minimize “wasted stops” and unnecessary delays to vehicles. Trials with this secondary level of detection have not always been successful, as some pedestrians wander near the pedestals but outside the range of the secondary detector, leading to the cancellation of their call. If genuine calls are canceled too often, some pedestrians think the crossing is faulty and they ignore it and cross regardless. This is not good for safety at the site, or for overall consistency and trust between engineers and users across a network. Curbside detectors are therefore not recommended for PUFFIN crossings on CAREC roads at this time.

Pedestrians will welcome the introduction of PUFFIN crossings on CAREC roads.

7. Pedestrian push-button activation

176. Push-button detectors are the most common form of activation for pedestrians to register their demand to cross a road. These are usually mounted on the signal pedestal at each end of the signalized crosswalk.



Features of good pedestrian push buttons. Good push buttons are robust and easy to activate. They reassure pedestrians with a call record indicator, and they help the sensory-impaired with audio-tactile features. Stickers on the pedestal inform pedestrians about the signal operation and how to correctly use the crossing.

177. Consistent placement of push buttons across a road network is important in getting pedestrians accustomed to using these helpful devices. For consistency across a network, the push buttons should be

- clearly visible to approaching pedestrians, and not obstructed by street furniture;

- placed on the pedestals that hold the pedestrian signals (typical locations for push buttons are shown in Figure 12);
- placed at or near the curbside and facing toward pedestrians about to use the crossing;
- mounted on the median post in narrow medians, with the face parallel to the signalized crossing;
- located not more than 1 m outside the projection of the signalized crossing and not more than 2 m back from the curb line at the signalized crossing (a separate push-button post should be installed if no traffic signal pedestal is in a suitable position);
- mounted $1\text{m} \pm 0.1\text{m}$ above the footpath level (to suit all ages, plus those in wheelchairs); and
- installed in such a way as to avoid confusion about which button applies to which crossing where there are two crosswalks on a corner.

178. There are numerous types and makes of pedestrian push buttons available, but the best ones have several key features (Figure 13):

- A large button that can be pressed easily by pedestrians of any age, including the mobility impaired.
- A call record indicator to reassure the pedestrian that the call has been recorded. In some traffic situations with long cycle times, pedestrians become frustrated if they think the signals have failed to record their call. The indicator gives them reassurance: when the button is pressed, an illuminated disc or panel (the

Figure 12: Push-Button Location and Orientation

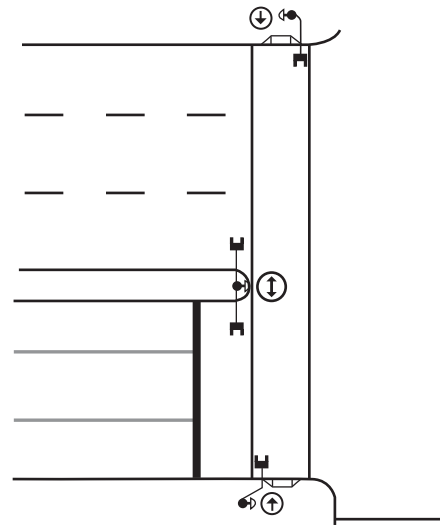

Source: AUSTRROADS (2020).

Figure 13: A Typical Pedestrian Push-Button Arrangement

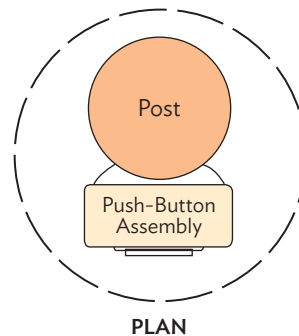
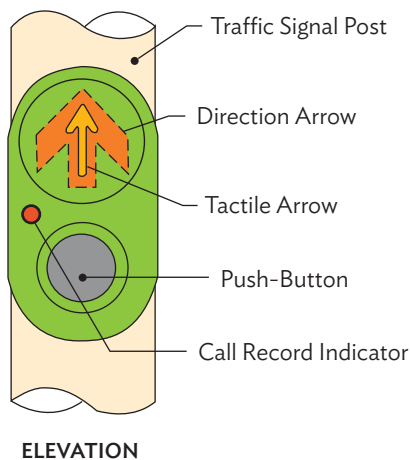

Source: Land Transport New Zealand (2007), page 15. 20.

pedestrian demand indicator) will indicate to the pedestrian that his or her demand has been recorded by the controller. The illuminated panel switches off when the demand is satisfied (when the Walk signal appears).

- Audio-tactile facilities to assist sensory-impaired pedestrians. The audio feature is designed to help visually impaired pedestrians, but it can also serve as a prompt for sighted pedestrians who have learned to rely on it. The tactile feature is usually in the shape of an arrow that points in the direction of the active crossing. This is important at intersections where two call buttons for different crossing directions may be close together. More details are provided in section D.8.
- Robust and sturdy construction, to make them vandal-proof and weather-proof.

179. In more recent models, in addition to push-button detection, controllers may also be set to register a fixed demand for any pedestrian movement so that the movement runs in each cycle (whether called or not). This should be considered only where pedestrian volumes are high, and the cycle time is long enough to accommodate all phases with pedestrian movements, such as in central business areas at busy times during the day. Automatic introduction may be invoked by time of day, or on condition that the coordinated signal cycle time exceeds a certain value.

8. Audio-tactile pedestrian devices

180. To assist sensory-impaired pedestrians, it is now common practice to install pedestrian push buttons with audio (sound) and tactile (touch) components. In some countries, providing these devices at all signals is required by law (under the Disability Discrimination Act or its equivalent). In any case, it is good to provide these devices across the network to assist sensory-impaired and elderly pedestrians.

181. Audio-tactile push-button detector units emit a distinct beeping sound, but some may be programmed to include the sound of tweeting birds or synthesized human voices. The beeping is slow and continues in the background until the Walk signal starts, at which time it increases in volume and speed. Then during the pedestrian clearance time, the sound decreases in volume and in speed (frequency). In many cases, sighted pedestrians (some of whom may be distracted by their phones or other things around them) are prompted to cross by this sound rather than by the Walk signal itself.

182. Visually impaired people can use the steady sound as a “homing” signal to locate the push-button detector. They know it is time to cross the road when the unit produces a series of fast beeps. The faceplate of the audio-tactile push button unit pulses in time with the audio sounds, providing the tactile indication to cross for those who are both visually and hearing impaired.

183. Audio-tactile pedestrian devices should consistently include the following features and applications:

- All push buttons should be located within the same parameters as detailed above.
- A tactile arrow should be on the face of the push-button assembly. This gives guidance to those with visual disabilities. The arrow should point toward the associated crosswalk lines.
- Where one push button is mounted in a narrow median, the tactile arrow should be a horizontal double-headed arrow parallel to the crosswalk lines.
- Audio-tactile push buttons should not be closer than 2 m from one another to avoid confusing a visually impaired pedestrian. For this reason, having two push buttons on one pole is not suitable for audio-tactile push buttons.

Provide consistently good pedestrian facilities across the road network.

E. Passive time separation crossings

184. A passive crossing is one where the driver is required to give way to pedestrians seen on the crossing. There are no red traffic signals at passive crossings to direct the driver to stop, either with or without pedestrians. Passive crossings must therefore be conspicuous with clear sight lines. Because their effectiveness depends on the readiness of drivers to give way (and this is subject to interpretation), passive crossings benefit from consistently good police enforcement.

1. Pedestrian (zebra) crossings

185. Pedestrian (zebra) crossings are low-cost facilities that give right-of-way to the pedestrian over the motor vehicle once the pedestrian has stepped onto the



Some variations of common pedestrian push buttons. Instead of push buttons, some pedestrian detectors can have infrared detection with a range of about 10 centimeters which does not require touch activation. Other detectors can recognize a "seniors card," which extends the clearance time for pedestrians who need it. In the United Kingdom, push buttons have built-in pedestrian signals, giving better guidance closer to the waiting pedestrians.



Audio tactile pedestrian push button. The most useful pedestrian detection units have a large push button for easy use, an audible signal to assist the visually impaired, and a tactile unit to assist the visually or hearing impaired. The orientation of the tactile arrow points the visually impaired in the direction of the crossing. The center of the arrow pulses slowly until the start of the pedestrian phase, when it increases to match the audio.

Audible signals. Some pedestrian signals do not have push-button activation, but they do include an audible signal to help the visually impaired know when to cross. This unit is linked to the signals and emits a clear beeping sound during the Walk time.

crossing. They are a passive form of time separation in that the driver needs to see the pedestrian on or near the crossing to decide to slow down and give way. For this reason, zebra crossings must always be very conspicuous and sight lines to and from the crossings must always be clear, during both day and night. They are best suited to low-speed environments such as local residential streets, collector roads, and car parks, where speed is managed. Traffic calming (described in Chapter VII of this manual) helps manage speeds on local streets, thus setting up a good environment for the use of zebra crossings.

186. Pedestrian (zebra) crossings vary slightly from country to country, but they typically feature broad striped markings on the road (usually white, but

sometimes yellow), and regulatory signs facing the drivers. Some cities make the crossings more visible by using red or yellow pavement markings to highlight the white zebra markings. Others place their zebra crossings on road humps to manage vehicle speeds, make the crossings more conspicuous, and elevate pedestrians above puddles on wet days.

187. Zebra crossings work well in conjunction with curb extensions and pedestrian refuges. As at all other crossings, pedestrians appreciate having curb ramps for stepping on and off these crossings. Good streetlighting is essential at night, and additional floodlighting is highly desirable for some of these crossings. Because drivers can give way to pedestrians



Pedestrian (zebra) crossings. Pedestrian (zebra) crossings are relatively low-cost and passive devices rely on the driver to comply with road rules and give way to crossing pedestrians. Zebra crossings must be well maintained, and road rules at these crossings must be consistently enforced by the police.

on a zebra crossing only if they see them, there must be good sight lines to and from the crossing. Vegetation must be maintained, and parking must be managed, near all zebra crossings.

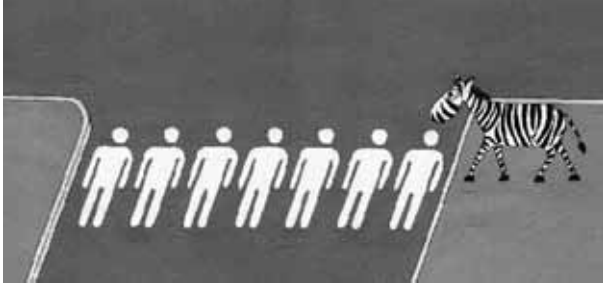

188. The following factors should be considered when designing pedestrian (zebra) crossings:

- Zebra crossings should not be placed on roads with more than one lane in each direction (except perhaps in low-speed environments with speeds of around 30 km/h). Multilane roads are wider, expose pedestrians longer to the risk of a collision and encourage overtaking, to the possible detriment of pedestrians on the zebra crossing, who may be hidden from the overtaking driver's view by the stopped vehicle being overtaken. Serious collisions can occur as a result.
- Such crossings should not be needed on rural roads (with their low traffic volumes and dispersed pedestrian numbers), but they should also not be placed on roads with operating speeds exceeding 60 km/h.
- Zebra crossings are best suited to locations with steady, but not high, pedestrian volumes, coupled with low vehicle speeds and low to medium traffic volumes.
- Large numbers of pedestrians can excessively delay traffic. When pedestrian volumes exceed 500 pedestrians per hour, it often becomes necessary to consider installing POSs instead.
- Zebra crossings require clear sight lines between pedestrians and drivers.
- These crossings rely on good driver compliance.
- Curb extensions help improve safety and compliance. (Be seen, be safe.)
- Zebra crossings benefit from the addition of civil works (footpaths, refuges, curb ramps, antiskid surfacing, and bridges over drains).
- All zebra crossings should have overhead floodlighting.

Never install a zebra crossing on a road with operating speeds over 60 km/h.

189. Zebra crossings rely heavily on good compliance by drivers—a factor that is too often missing in some CAREC countries. Many pedestrians defer to the vehicles for fear of being struck. In these conditions, many drivers no longer expect to give way at these crossings; some may not even be aware that the road rules require them to do so. Many zebra crossings thus fail to deliver on their primary objective of giving the pedestrian temporal (time) separation.

190. This fundamental safety concern becomes worse on multilane or other high-speed roads. Some design engineers, trying to help passengers get to and from their bus or taxi stops in high-speed rural sections of new CAREC highways, have designed stops with shelters, indented bays, and zebra crossings. Although well-intentioned, this move perpetuates the false thinking that a zebra crossing on a rural highway will be helpful to pedestrians. But a driver traveling at 100 km/h on the new highway is unlikely to stop and give way to a pedestrian who steps onto that crossing. The driver may not see the pedestrian in time (at 100 km/h, the vehicle is traveling at 28 m/sec), or may be concerned about being struck from behind if the vehicle were stationary on the high-speed road. Whatever the reason, pedestrians gain nothing from the zebra crossing in these situations. They will soon learn to depend on their own judgment when selecting a gap in traffic, not expecting the zebra crossing to give them priority over motor vehicles.

191. Zebra crossings should be installed only in locations where pedestrians need to create a gap in traffic to cross the road. If traffic volumes are low, there will usually be plenty of such gaps, lasting long enough for pedestrians to cross without needing a crossing. If speeds are high (above 60 km/h), it becomes doubtful whether drivers will give way to pedestrians on a crossing. On multilane roads, a slow or stopped vehicle in one lane can conceal a fast-moving vehicle in the next lane. So there are practical limits to where zebra crossings can safely be installed, and an engineer should remain open to the idea that, in some locations, pedestrians may be safer *without* a zebra crossing.

192. In short, with very few exceptions, zebra crossings should not be used on any road with an operating speed above 60 km/h; lower operating speeds are preferable. For situations such as those outlined above for rural high-speed highways, it would be safer overall to install duplicate pedestrian warning signs combined with good sight lines in both directions, and maybe an overhead streetlight or two. If the highway is divided, a clear path across the median will help to focus pedestrians to one point. Pedestrians would not have right-of-way, but drivers would be alerted to their possible presence, and pedestrian safety would be better served.

193. In summary, for the safety of pedestrians, zebra crossings should not be used on busy arterial roads, across high-speed roads (with operating speeds above 60 km/h), or on multilane roads (where speeds cannot be guaranteed to stay at or below 30 km/h). This last restriction is added because pedestrians crossing a multilane road (with two lanes or more in each direction) may not realize that a slower or stopped vehicle in one traffic lane is obstructing their view of an overtaking vehicle in the neighboring lane.



Some locations are too hazardous for a zebra crossing. There are practical safety limits to where zebra crossings may be used. In some locations, pedestrians will be safer without a crossing. Zebra crossings should not be used on high-speed roads, or on wide roads with two or more lanes in each direction.

Never install a zebra crossing on a road with more than one traffic lane in each direction.

194. It is recognized that the zebra crossing is the most common crossing in CAREC countries and that many of these exist on multilane roads, on high-speed roads (urban and rural), and on busy arterials. Some of these may now be decades old and may have been installed before traffic volumes and speeds reached their current levels. It is also recognized that removing all of these will not be practical, and upgrading them, not readily achievable. Instead, it is suggested that each of these existing crossings on multilane roads, busy arterials, or high-speed roads be inspected with a view to making changes or improvements in each one, within practical constraints and local limitations. To start with, the following options could be explored for each zebra crossing:

- upgrading the zebra to an active crossing (such as a POS or PUFFIN crossing);
- constructing curb extensions to reduce the crossing width and to make the pedestrians and the crossing easier to see;
- installing a pedestrian refuge to reduce the crossing width, improve pedestrian conspicuity, and provide storage space;
- installing floodlighting to highlight the crossing at night;

- reducing the speed limit or introducing traffic calming along the street to manage speeds, or both;
- placing the zebra on a hump, and putting up appropriate signs;
- maximizing all warning and regulatory signs on both approaches to the crossing;
- adding fluorescent borders to the regulatory pedestrian crossing signs, for increased conspicuity;
- installing 50 m of antiskid overlay on each approach to the crossing;
- maintaining the crossing in excellent condition (with suitable signs, markings, and lighting); or
- considering a package of improvements that could include more than one of these options, and possibly other treatments as well.

195. Setting a level of driver compliance that will give pedestrians the confidence to use these facilities requires consistent application of road rules and police enforcement. Road authorities should not install a zebra crossing unless it is certain that pedestrians on the crossing will have priority (time separation). This will happen only if and when drivers comply with the road rules.

Consistently good police enforcement is critical for pedestrian safety.



Making a zebra crossing safer. A fluorescent border can make a pedestrian-crossing sign more visible (left photo). Changing the color of the line marking (if supported under the road rules) and placing the crossing on top of a road hump (right photo) can enhance the conspicuity of pedestrians for drivers at a crossing and, in turn, promote driver compliance with the road rules.



Good maintenance of crossings is essential. Safety requires well-maintained crossings. If signs are missing (left photo) or lines are worn out (right photo), a crossing may no longer be a legal device (under national road rules). If so, pedestrians have no priority over vehicles, and in the event of a collision, they may have no legal recourse.

196. But all is not lost, as there are positive signs from some CAREC countries where consistently good police enforcement at zebra crossings is paying off. Drivers are slowing down, stopping, and giving way to pedestrians at zebra crossings in those countries, as required under the road rules. But the police need support from engineers through good maintenance of the infrastructure. Poor maintenance can lead to worn-out markings or missing signs, thus reducing the legal effectiveness of the crossings. But the biggest challenge for all is driver compliance with the national road rules at zebra crossings. As these crossings are installed to give pedestrians their own small part of the road network where they can expect priority over motor vehicles, one must then question the value of these crossings. Careful thought should be given to the use of pedestrian (zebra) crossings, as they do not, on their own, improve safety.

197. The safety of zebra crossings is often debated in engineering circles. Research from New Zealand showed that a zebra crossing, without other safety features, *increases* pedestrian crashes by 28% on average, compared with locations without a crossing. However, zebra crossings placed on top of a road hump *reduce* pedestrian crashes by 80%. This latter figure closely matches a more recently derived crash reduction factor of 73% of pedestrian crashes due to a zebra crossing on a road hump (Appendix 2).

Crossings placed on humps are safer overall for pedestrians.

2. Part-time passive crossings for a specific use

198. Schools, childcare centers, and places of worship are some of the places that may press for a crossing for children, students, or other people to use, even if just for a few minutes each day, on a few days each week or month. Approving and installing a crossing under these conditions can be challenging for the road authority, as the only crossings approved and installed these days are regulatory crossings that are used 24 hours a day, 7 days a week. Installing one of these crossings where it will remain largely unused most of the time can lead drivers to ignore its existence. Across CAREC, the most common option in these situations at present is installing a pedestrian (zebra) crossing for schoolchildren, sometimes with an adult supervisor. There is some merit in using these crossings, as they are included in the road rules, and drivers and pedestrians should therefore be familiar with them. However, the question whether there are better, safer, more effective devices for such part-time situations should also be asked.

199. On local streets with low traffic volumes, a “time separation” facility is usually unnecessary. Small civil works, such as curb extensions, refuge islands, and parking restrictions that allow for clear sight lines, can achieve as much as, or more than, a zebra crossing, provided that traffic speeds are kept low. Traffic calming can help keep speeds low and deter unnecessary through traffic. But on collector roads, or busier residential streets, which option is best? Can a low-cost, part-time pedestrian facility be designed

to serve pedestrians who need assistance only at selected times?

200. To answer these part-time needs, some countries have developed “part-time” crossings, mostly for schoolchildren going to and from school. These part-time crossings share common principles:

- marked crosswalks (to define the crossing);
- advance warning signs (to warn approaching drivers);
- a device, signal, flag that is displayed to indicate when the crossing is “in operation” (when it is not displayed, the crossing is not operational);
- someone to make the device operational (position the flags, or switch on the flashing signal);
- possibly an adult supervisor to assist young pedestrians; and
- consistent design and installation across the province or country.

201. Typical questions that could arise with this concept in CAREC countries might include the following:

- Why would any CAREC country want to introduce a new crossing, even at low cost?
- Why not continue using zebra crossings for these situations?
- Would drivers understand and respect the new crossings?
- If the school, childcare center, or place of worship has an event on a different day than usual, what would drivers do?

202. It is apparent that many zebra crossings are not respected, and that drivers are given little information about the different uses of zebra crossings. Some serve large shopping centers and are used all day and all night, others are for schools and are used twice daily, and still others, in villages, are little used. So a low-cost crossing that is intended specifically for schoolchildren will at least capture more driver attention than the myriad zebra crossings.

203. This idea is considered in this manual so that readers will think more broadly about their pedestrians and the crossings they typically use. Such new, part-time crossings may or may not be needed right now. But in time, different situations will arise and the community will welcome clear-thinking, innovative engineers who can provide a facility that serves all groups.

204. One possibility involves a pair of marked crosswalk lines, with a stop line on each side, and four upright wooden posts on which two Children Crossing flags are displayed when the crossing is to be used. Without the flags, this is just another piece of the road. But when the flags are displayed, the road rules are clear: a driver must stop and give way to any pedestrian, child or adult, on the crossing or about to enter it. These crossings may have an adult supervisor, and may be placed on a flat-topped road hump. Some may have curb extensions on one or both sides of the road, and all will have curb ramps leading onto them. This solution is low-cost, and one that is highly effective.



Part-time crossing. This photo shows a road for left-side driving. This part-time crossing (a crossing for children) has road markings and posts but becomes a formal crossing only when flags are displayed. Some of these crossings (including this one) are on road humps, and some are supervised by an adult. Other part-time crossings include flashing lights that are switched on for the times needed. All part-time crossings should be defined in national road rules.

F. Helping pedestrians walk safely along rural roads

205. One feature of rural CAREC roads is the large number of pedestrians who use them. On those roads, pedestrians walk to and from school, work, home, bus stops, and other destinations. Pedestrians like to walk on smooth, dry surfaces, and they enjoy walking along the paved roads when traffic volumes are low, stepping off only when there is an approaching vehicle. They dislike and avoid wet or muddy unpaved shoulders. Unfortunately, paved shoulders are often regarded as “optional extras” by highway designers in new road projects. Instead of viewing them as an integral part of a modern, safe road, too many designers still see paved shoulders as a feature that can be reduced in width, or

eliminated outright, to save money. Is it better to build 20 km of new road without a paved shoulder, or 15 km with a paved shoulder? This can be a tough question, but because pedestrian safety and convenience should be central considerations in the planning and design of rural road projects, the benefits of paved shoulders must always be part of the answer. Ignoring these is false economy. National standards must be reviewed and updated, and over time, rural roads should be retrofitted with new or wider paved shoulders.

1. Separate footways

206. The use of separate footways for pedestrians (and bicyclists) within the road reserve but well removed from the road is an option with many safety benefits. Provided that the road reserve has sufficient width, a separate “all-weather” footway along one or

both sides of the road can offer a shady and safe path for pedestrians. Such footways offer opportunities for pleasant walking, away from motor vehicles, but they do need to be continuous and they benefit from lighting for use after dark.

2. Paved shoulders

207. Paved shoulders, preferably 1.5 m wide, are one of the best road safety initiatives for all users of rural roads. They provide several benefits:

- better protection for the road pavement and sub-grade against water damage;
- a better chance for drivers to take evasive action (and to avoid head-on or run-off-road crashes);
- an all-weather path separate from motor vehicles on which pedestrians can walk;



Pedestrians walk along many CAREC roads. Although pedestrians prefer to walk on smooth dry surfaces and will avoid muddy shoulders, paved shoulders are often seen by highway designers as “optional extras,” an area where costs can be reduced by keeping the shoulder widths to a minimum (such as 500 mm). This is false economy. Minimizing or doing away with paved shoulders can increase road-user vulnerability and heighten the risk of crashes. It can also shorten the life span of the pavement.

- a smooth surface set apart from motor vehicles on which bicyclists can ride;
- space separate from motor vehicles for other small or slow vehicles (including agricultural machinery) and animals;
- dust suppression;
- reduced risk of a sharp drop-off from the pavement edge (safer for two-wheelers in particular); and
- a useful emergency stopping place (for attending to a punctured tire or car breakdown, or an illness).

208. Some people are concerned that drivers may use paved shoulders as extra lanes. This usually happens only when traffic volumes are high, or when slow-moving motor vehicles disrupt traffic flows. Paved shoulders are not for the passage of motor vehicles, so the practice is not to be encouraged. But this matter is best addressed through public awareness campaigns and police enforcement. Ignoring the use of paved

shoulders for this reason is refusing to take notice of the many advantages they offer. Besides the stated benefits, footpaths and paved shoulders combined have an 88% crash reduction factor for pedestrian crashes (Appendix 2). To help pedestrians walk safely along rural roads, the best thing to do if there is no space for a separate footway is to provide them with paved shoulders of generous width (1,500+ mm).

Paved shoulders, preferably 1.5 m wide, are one of the best road safety initiatives for all users of rural roads, including pedestrians.

VI. Civil Works to Assist Pedestrians

209. Numerous small-sized civil works can improve pedestrian movement and safety. These works may be part of a larger project, may be built when a new crossing is installed, or may be undertaken as a package of minor improvements across the network to assist pedestrians and to enhance their ability to walk around their city or town. These are not high-tech measures, just functional, practical, and low-cost projects, tried and tested, and used by countless people everywhere, every day. Without them, pedestrian mobility is reduced, and pedestrians using the footpaths and streets are at greater risk of injury. These civil works are the small, unimposing items of infrastructure that are easily taken for granted—until they are not where they are needed. They support the more obvious and high-profile pedestrian facilities (like pedestrian overpasses, subways, PUFFIN crossings, and POSs). This chapter provides guidance on these matters. It encourages engineers and road authorities across CAREC to walk the streets and footpaths of their cities and towns and to develop a program of minor works that can make each city or town more pedestrian-friendly and more pedestrian-safe.

A journey of 1,000 kilometers begins with a single step.

A. Footpaths

210. Footpaths (also called sidewalks or walkways) are routes within the road reserve, separate from motor-vehicle traffic, on which people walk. They improve pedestrian mobility, as they connect homes, shops, schools, offices, parks, and public transport stops. Footpaths are so common that they are often taken for granted, and it is only when a footpath is in poor condition, or does not exist, or has a missing section that people realize how useful footpaths really are. An “all-weather” footpath should be a part of every street and road in urban areas, creating a pedestrian network for the CAREC region. A good pedestrian footpath network is

- continuous, with routes that are as short as possible, giving good access to key destinations, including public transport stops;
- aligned directly with good road-crossing points, where waiting times are kept to a minimum;
- set well back from motor-vehicle traffic;
- well lit;
- wide enough to minimize conflicts between users;
- clean and free of litter, with seats, a shelter, and rest areas;
- enjoyable to walk on; and
- well suited to use by all road users, especially the disabled.

211. Roadsides accommodate features other than footpaths, so it is important to provide enough room for all these features, and to give pedestrians a clear space in which to operate. Attention to the effective width of the footpath is one issue for designers to consider. Vegetation or street furniture can take over some of the width of a footpath and can have a greater impact on some users than on others. As Figure 14 and the photo below that show, if the vegetation continues to grow, the clear footpath width will eventually be too narrow for some users, especially wheeled pedestrians.

Figure 14: Required Footpath Width

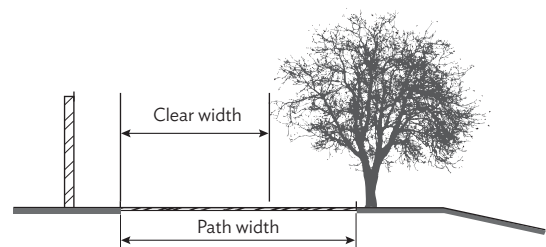

Note: Footpaths need a clear width that suits all users. Overgrown vegetation (see photo below) can reduce the clear width below minimum requirements.
Source: AUSTRROADS (2017c), page 25.



Footpaths. Footpaths must be well maintained. Overgrown vegetation can reduce the effective width of a footpath, and be a special challenge for wheeled, and sensory- or mobility-impaired, pedestrians. Large holes are an inconvenience for some people but a major obstacle for disabled pedestrians.

212. A well-designed footpath should be

- flat, with an all-weather surface (concrete, asphalt, or compacted crushed rock);
- nonslip in wet, snowy, or icy weather;
- at least 1.2 m wide, and much wider where space permits and volumes demand (see Table 9);
- continuous, and preferably on both sides of the street;
- accessible to all, including those in wheelchairs and on crutches;
- free of obstructions (such as hydrants, signs, seats) and snagging hazards;
- more than 2 m away from the nearest traffic lane;

- adequately drained, with a 1%–2.5% cross-fall for paved paths (a steeper cross-fall may cause problems, especially for elderly, mobility-impaired, and wheeled pedestrians); and
- well maintained, so that the surface is safe for all (no potholes) and the clear width matches the path width (see Figure 14).

213. These widths should be increased at locations where

- high pedestrian volumes are anticipated;
- the pedestrian path is adjacent to a traffic or parking lane;
- the pedestrian path is combined with bicycle facilities;
- the pedestrian path is to cater to people with disabilities; or
- overtaking of path users is expected.

Table 9: Width Requirements for Pedestrian Paths

Situation	Suggested Minimum Width (m)
Low pedestrian volume	1.2 m is the general minimum for most roads and streets, and is the clear width required for one wheelchair
High pedestrian volume	2.4 m (and wider for higher volumes such as in commercial and shopping areas)
For wheelchairs to pass	1.8 m
For people with other disabilities	1.0 m

m = meter.

Source: AUSTRROADS (2017c).

B. Removal of tripping and snagging hazards

214. It can be surprising what items are left or placed on footpaths and along roadsides. Many of these can trip or snag unsuspecting pedestrians as they pass. Some common examples are as follows:

- uneven paving stones or concrete paving slabs;
- poorly restored footpaths after trenching or maintenance works;

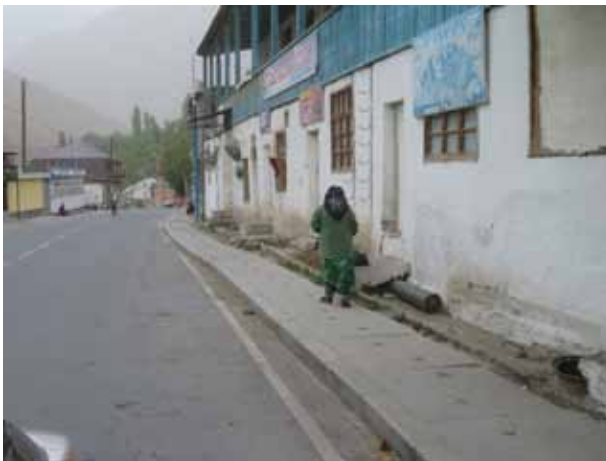

Functional footpaths. Footpaths should be as wide, flat, and smooth as practical, and have an all-weather surface. Footpath surfaces that minimize the risk of slipping in wet or icy conditions should be a key factor for CAREC cities and towns. Functionality is the key to good footpaths, and good footpaths encourage walking.

- tree stumps that are not fully removed after the tree is cut;
- signpost bases left behind when signs and posts are removed;
- uneven pit covers, or cover-lifting handles;
- poorly placed, or inconspicuous, street furniture;
- remnants of old pedestrian fencing or safety barriers;
- steps into adjacent buildings;
- driveways at levels different from the footpath level;
- tree roots, rocks, and landscaping;
- shallow areas where ice forms (and other slippery tiled areas);
- street signs installed too low (cutting or scratching the heads of taller pedestrians);
- illegally parked vehicles; and

- overgrown vegetation (from private gardens and from street landscaping, catching or snagging clothing, legs, and arms).

215. There are many more hazards as well. Engineers should put themselves in the shoes of their customers and inspect the network of footpaths and other facilities under their responsibility.

216. Removing these hazards, and repairing the paths, improves these pedestrian facilities and can prevent many incidents. Most of these are quite minor, but sometimes, and especially when senior citizens are involved, tripping and snagging hazards can lead to fractures and long-term injuries. Regular maintenance of footpaths and places used by pedestrians should be an ongoing activity of the local government and the road authority. Much can be done at modest cost.



Inspect regularly. The site should be inspected day and night, and a close search should be made for unnecessary items in the footpath that can trip or snag pedestrians. Remnants of concrete blocks, illegally parked motor vehicles, and uneven, icy footpaths are common tripping or snagging concerns in CAREC cities and towns. Some are more obvious than others, but all can injure pedestrians and discourage walking.

C. Curb ramps (smooth crossovers)

217. Curb ramps provide smooth access between the footpath and the road for people in wheelchairs and for those using strollers, walkers, or handcarts. Curb ramps are useful places for pedestrians with mobility restrictions to move from the road to the footpath, or vice versa, without having to step onto and off high curbstones. Curb ramps with a smooth change in level between the pedestrian path and the road pavement allow safe and easy access for pedestrians, including the mobility-impaired and those with personal mobility devices.

218. A curb ramp (sometimes called a smooth crossover or a pram crossing because it assists parents with prams) can guide pedestrians to an approved crossing point. For this reason, curb ramps should be

uniformly provided at all locations where pedestrians need to cross a road—with a crossing facility or without.

219. All new road projects should include curb ramps as a standard part of the works. In addition, a positive and relatively low-cost initiative would be to inspect the road network and to set up a program of works for the construction of curb ramps where these are needed. Curb ramps are needed on all urban streets, and in selected places on rural roads, but they are needed most to serve wheelchair users and other mobility-impaired groups. An annual program of constructing new curb ramps should focus on places used by the disabled and the elderly, as well as on high-volume locations in busy shopping centers, and at schools, hospitals, places of worship, and bus stops. Even if the annual budget can support only a handful

of curb ramps, an improved ambience for pedestrians will soon develop in the urban area.

220. Curb ramps (a typical design is shown in Figure 15) should

- have a smooth antislip surface with a maximum slope of 1:8 (desirably less);
- have a flatter curb ramp grade (such as 1:10) with tactile ground surface indicators (TGSIs), providing a smoother transition between the road pavement and the path;
- be oriented at right angles to the road (to guide visually impaired pedestrians onto the crosswalk);
- be aligned and continuous with the curb ramp on the other side of the road;
- have enough width for the expected volume of pedestrians;
- not have sharp sides;
- not have a vertical lip at the edge of the drainage channel, as this inhibits the free movement of wheelchairs; and
- have good surface drainage to avoid low points and the accumulation of water in the pedestrian crosswalks. For example, drainage inlets should be placed on the road immediately upstream of ramps to minimize the water that passes through the channel at ramp crossings.

221. The gradient of 1:8 allows a vision-impaired pedestrian to identify the grade change without the assistance of TGSIs. If it were flatter, the visually impaired person may not recognize the grade change and could stumble or trip. Such incidents could result in more widespread use of TGSIs, which is undesirable to many wheeled pedestrians. Constructing a lip at the drainage channel or line of curb should be avoided, to allow the free movement of wheelchairs. Surface grading for drainage at intersections should be designed to avoid low points and the accumulation of water at crosswalks and curb ramps.

D. Tactile ground surface indicators

222. Tactile paving (also called TGSIs, tactile walking surface indicators, or detectable warning surfaces) is a system of textured tiles placed on footpaths, steps, railway station platforms, and other public areas to assist pedestrians who are visually impaired. Tactile warnings provide a distinctive surface pattern that is detectable with a cane or by foot, to alert the visually impaired to a conflict or hazard ahead (a street, or steps, or a change of grade), or to the point where a change of

Figure 15: Example of a Curb Ramp Design

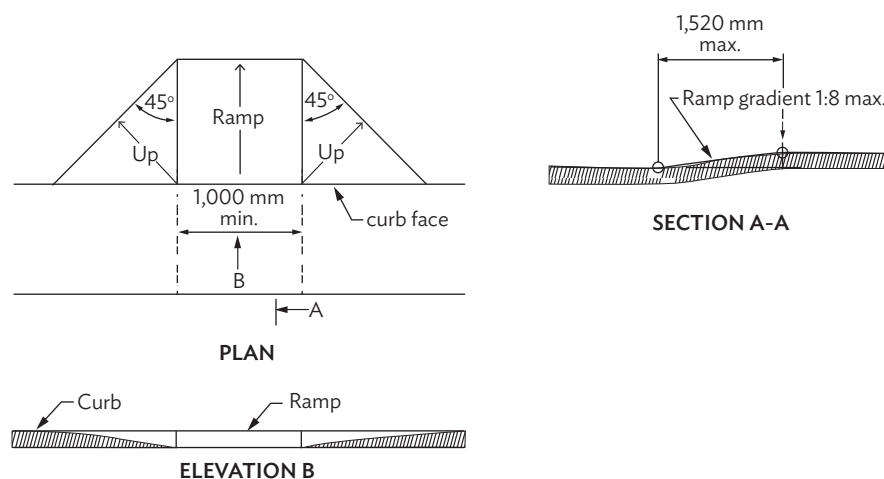

max. = maximum, min. = minimum, mm = millimeter.
Source: AUSTRROADS (2017a), page 60.



Curb ramps are desirable features. Curb ramps (with or without a crossing) assist mobility-impaired pedestrians, wheeled pedestrians, and parents with pushers. They help define the crossing point and, by channeling pedestrians to one place, they help drivers become more aware of crossing pedestrians. The ramp should be wide enough to serve the demand, and the gradient (1:8 maximum) must serve wheeled users.

direction may be required (a turn from a footpath toward a bus stop).

223. Nonfade, nonslip, and nondelaminating TGSIs are useful devices that assist the vision-impaired in navigating their own way with increased independence. Modern TGSIs (commonly called tactiles) are made from high-tech polyurethane, metal composites, or ceramics. They must be strong, durable, and functional under extreme conditions (from hot to freezing cold). Importantly, they must be uniform in design, size, and installation so that the visually impaired can gain maximum benefit from them. There are two types of tactiles, each serving a different purpose:

- **Dimple tiles**, the dotted form of tile (with raised nodes) are warning tiles. They are used to *warn* the visually impaired of an immediate conflict point.
- **Ribbed tiles**, the longitudinal form of tile (with raised ribs), are guidance tiles. They *guide* pedestrians to selected points, including places where they may want to change direction.

224. When planning to implement a program of tactile paving across a city, it is essential to use the paving units consistently, according to national guidelines (if any), and also to be consistent in serving similar places. Vision-impaired pedestrians rely on consistency to interpret accurately the cues provided by tactiles. Complying with national standards is an indispensable part of the product selection and installation process. To maintain consistency, several factors must be considered:

- uniformity of dimensions;
- accuracy of installation, including spacing precision and use of correct adhesive;
- luminance contrast, as many vision-impaired people still retain partial vision and can detect the contrast provided by suitably colored TGSIs; and
- slip resistance of TGSIs, especially in wet conditions, as these are often placed at hazardous locations such as bus stops, escalators, at the top of stairs, and at pedestrian facilities.

225. There are several basic considerations in the placement of nodal (warning) tactiles. These textured tiles are used

- to mark the top and bottom of steps and stairways, ramps, escalators, and moving walkways;
- to indicate hazards in open public spaces, including tripping hazards;



Use of tactiles. Guidance (ribbed) tactiles provide directional orientation in open spaces. They also guide users to a destination by indicating points of change of direction along a route. Warning (nodal) tactiles inform users of a hazard ahead.

- to indicate pedestrian and vehicle (usually bicycles) shared spaces where surfaces have the same grade and separation is required for safety;
- to indicate the start of road-crossing points, such as pedestrian crossings;
- to warn of potentially hazardous car park entry and exit points;
- to indicate embarkation points at bus stops, train stations, and ferry terminals, where a fall from the platform or wharf edge could be serious; and
- to delineate a wall that projects into the path of travel or any structure with an overhead clearance of less than 2 m (such as the underside of a flight of stairs) that is not isolated by a barrier.

226. Guidance tactiles (ribbed tiles) give directional orientation in open spaces in the absence of other directional cues, such as a wall or a fence. These indicators serve two functions. One is to “lead” the pedestrian along an accessible path of travel to a

service point, such as a help point or ticket office. The other is to intersect the accessible path of travel to give direction to points of reference not on the path, such as midblock pedestrian crossings, bus stops, or the entrance to an important public building.

E. Pedestrian refuges

227. Pedestrian refuges are raised islands, usually in the middle of a road, where pedestrians can safely wait for a gap in the traffic so they can finish crossing the road. Refuges make crossing the road easier and safer for pedestrians by allowing them to cross in two stages. Crossing one direction of traffic at a time reduces pedestrian delays by up to 90% and safety is also enhanced. Studies (Appendix 2) have shown that pedestrian refuges reduce pedestrian crashes by 50%.

228. Pedestrian refuges are practical devices that

- can be installed at low cost and require little maintenance;
- increase motorists' awareness of the possible presence of pedestrians;
- offer pedestrians a degree of physical protection;
- enable pedestrians to stand safely in the middle of the road and to look out for oncoming traffic in one direction of travel at a time;
- reduce pedestrian delays, and improve pedestrian safety;
- can be helpful in locations where a formal crossing could result in traffic congestion; and
- can be used in conjunction with time separation facilities such as pedestrian (zebra) crossings, PUFFIN crossings or POSs.

229. Pedestrian refuge islands are best suited for the following traffic conditions:

- Urban environments where speeds do not exceed 60 km/h.
- Two-lane, two-way streets. But they are also useful on wide, multilane roads.
- Locations where pedestrians cross a heavily trafficked road over a substantial length, such as on busy shopping streets. In those settings, several carefully spaced refuges will serve pedestrians better than a single crossing that may be hundreds of meters from where many wish to cross.
- Two- and four-lane roads, even if some localized widening may be required to fit in a refuge. When road widening must be done for that purpose,

adequate lateral shift tapers should be provided, and plenty of pavement hatching placed on each approach to assist conspicuity of the refuge island. A squeeze point should not be created for bicyclists.

- Places where pedestrians need help to cross a road but where a pedestrian (zebra) crossing may not be justified (because of road width or low pedestrian volumes).

230. When designing pedestrian refuges, it is necessary to consider the following design features:

- **Width.** Refuge islands should be at least 2 m wide (narrow refuge islands put pedestrians at risk of being hit by overhanging loads and truck mirrors). This is also the minimum width for pedestrians walking with their bicycle, or parents with a child in a pusher. Where pedestrian demand is higher, a 3 m width (or more) should be provided.
- **Length.** The pedestrian refuge must be long enough to be conspicuous to approaching drivers (minimum lengths of 10 m on side streets and 20 m on arterial roads are useful guides). It should also be long enough to accommodate the expected number of waiting pedestrians.
- **Level.** The pedestrian path and standing areas within them should be flush with the roadway to allow wheelchair users, people with prams, bicyclists, and all others to easily access the refuge without struggling over curbing. If this cannot be done, professionally designed curb ramps should be constructed.
- **Construction materials.** Refuge islands should be constructed as curbed islands (not just painted), and the surface material used should be noticeably different from that used for the road pavement.
- **Signage.** Warning signs and additional streetlights are necessary at each refuge.
- **Pavement markings.** Refuges should have pavement markings to ensure that vehicles are safely guided past the refuge island and that the roadway is not unexpectedly constrained. The number of traffic lanes on the approach should be maintained past the island; the line marking may have to be modified to reduce the lane widths, and parking controls imposed, for that purpose. If pedestrian refuges are needed at successive closely spaced intervals along a street, consideration should be given to providing a continuous raised median or a flush (pavement marking) treatment linking the separate islands.
- **Staggered crossings.** If the pedestrian refuge is used in conjunction with a pedestrian (zebra) crossing or a POS, a staggered path should be

introduced through the refuge to cause pedestrians to face approaching traffic on the side of the road they are about to cross.

- **Adequate illumination.** Refuge islands should, in all cases, be adequately lit in accordance with national streetlighting standards.

Pedestrian refuges and curb extensions are excellent, yet underrated, pedestrian devices.

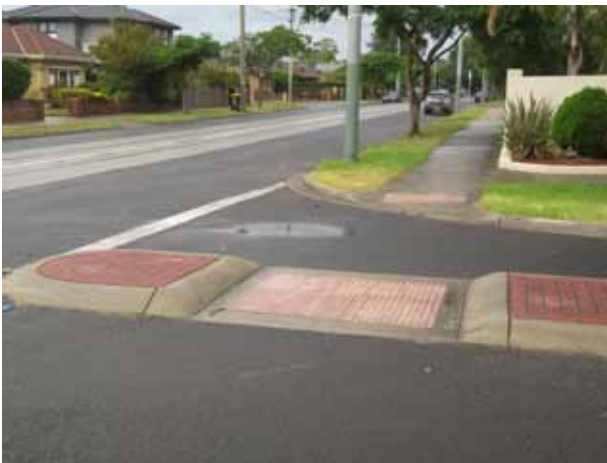

Pedestrian refuges. Pedestrian refuge islands should be visible, with hatching on the pavement at each end to clearly define them. Semi-mountable curbing allows easy pedestrian access and helps redirect, but not damage, vehicles in low-speed impacts. Good signage (typically Keep Right or Keep Left signs) adds a vertical dimension to the refuge and must be replaced after a collision. A cut-through walkway, flush with the road, helps funnel pedestrians while assisting the disabled, especially those in wheelchairs.

231. Refuges can be used in conjunction with curb extensions to further reduce the road width where this is necessary. It is important to provide openings or curb ramps on the refuge and on the footpaths approaching the refuge from either side of the road.

232. The height and location of signs and other road furniture must be selected to maintain clear sight lines for both pedestrians and drivers. In particular, the height of signs in the path of pedestrians should be at least 2 m above the top of the curb to avoid obstructing pedestrian movement. Care must also be taken to ensure that the line of sight between drivers and pedestrians is not obscured and that pedestrians, particularly small children, are not hidden behind traffic signs at critical locations. This often occurs because of Keep Right (or Keep Left) signs placed on narrow medians and pedestrian refuge islands. To avoid these problems, the signs should be raised or mounted lower.

233. Splitter islands at intersections can serve as refuge islands (especially to assist pedestrians in crossing a minor road), and they offer additional safety protection at these locations. They prevent corner-cutting by drivers and thus assist gap acceptance by pedestrians.

F. Curb extensions

234. Curb extensions are physical changes made in the curb line that extend the footpath or verge into the road and reduce the road's effective width (Figure 16). Curb extensions thus reduce the distance pedestrians must walk when crossing a road, they reduce pedestrian exposure to traffic, and they improve pedestrian safety.

235. Curb extensions offer many benefits. They

- allow pedestrians to see and be seen;
- discourage illegal parking close to intersections and crossings;
- help in formalizing angle parking;
- highlight midblock crossings and work well with road humps;
- can work well on selected arterial roads, provided that these do not need the curbside lane for a bus lane or for a peak-hour traffic lane.

236. A good curb extension will reduce the width of the street, both visually and physically. It can allow space for street furniture, and sometimes even some landscaping. However, a word of caution is needed, as some road furniture can become roadside hazards, and too much landscaping (without good maintenance) can obscure sight lines between

Figure 16: Layout for a Curb Extension with a Curb Ramp and TGSIs

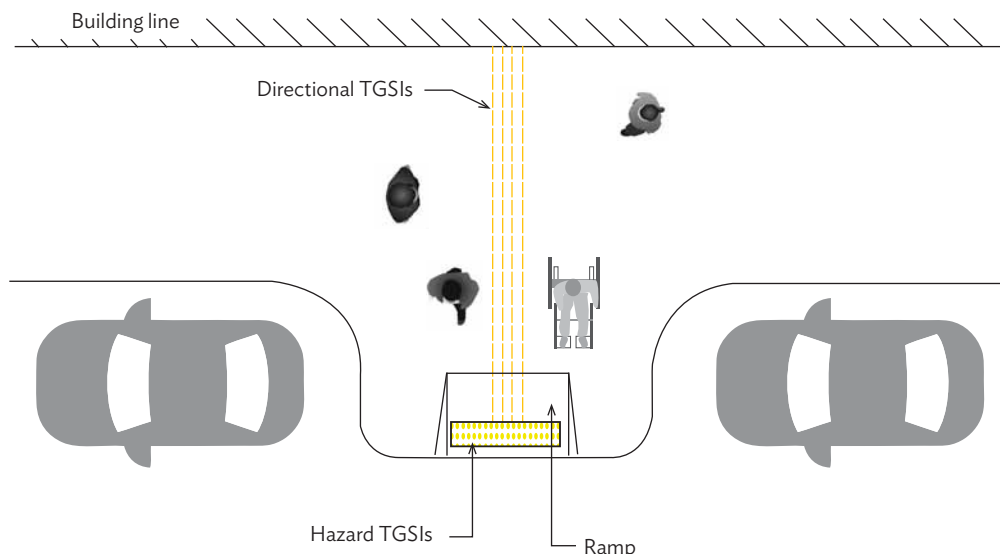

TGSI = tactile ground surface indicator.
Source: AUSTRROADS (2017a), page 58.



Curb extensions help pedestrians see and be seen. They may be placed at pedestrian facilities (such as zebra crossings, POSs, or PUFFIN crossings). They can be combined with pedestrian refuges depending on road width, although they work well on their own (usually in low traffic volume environments) where they reduce the road width for the pedestrians to cross.

vehicles and pedestrians. Curb extensions can be used on their own, at midblock locations or at intersections. They may also be combined with a formal pedestrian facility, including intersection signals, pedestrian (zebra) crossings (Figure 17), POSs (all variations), and even pedestrian refuges.

237. When placed at intersections, curb extensions help control parking and prevent vehicles from parking

too close to the intersection. Illegal parking at or near intersections is not only a serious contributor to pedestrian collisions but can also impede turns by large vehicles and emergency vehicles. By reducing the turning radius at an intersection, carefully designed curb extensions can slow down turning vehicles, further reducing risk to pedestrians. Curb extensions also create extra space for curb ramps and may help provide a more level footpath. But curb extensions

Figure 17: Curb Extensions Used in Conjunction with a Pedestrian (Zebra) Crossing

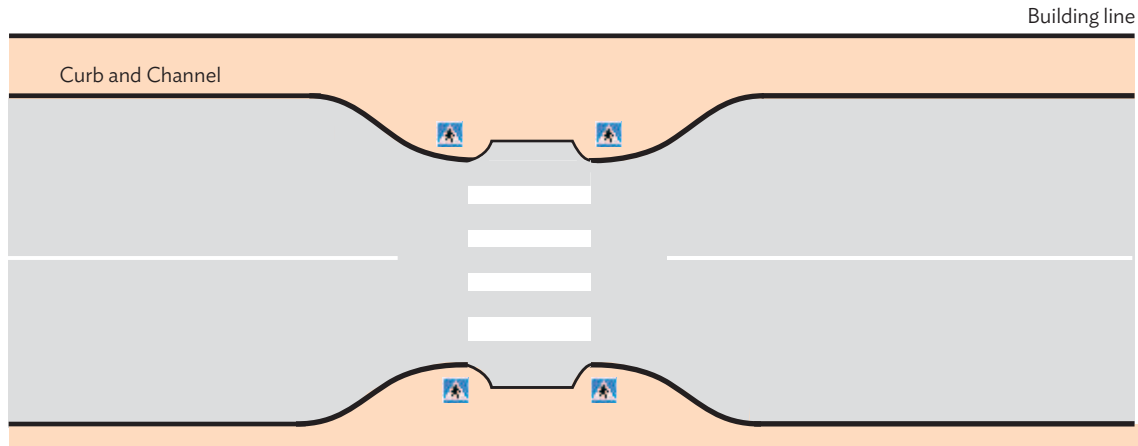

Source: Asian Development Bank.

cannot be installed everywhere. They are generally suitable only where there is an on-street parking lane. They should not be constructed in bus lanes or other traffic lanes, where vehicles could hit them.

238. In summary, curb extensions improve safety for pedestrians and others at intersections and at midblock locations. They funnel pedestrians to a crossing point and allow them to see and be seen, they reduce crossing distances (and thus crossing times), and they help control vehicle parking. Curb extensions are low-cost and low-maintenance devices.

G. Medians

239. Medians are designed and constructed to create divided roads and highways. Their main purpose is to separate the two directions of traffic and to control the locations where left turns (right turns in Pakistan) and U-turns can be made. In this way, medians provide a permanent form of control over the maneuvers of motor-vehicle drivers.

240. Medians are rarely, if ever, constructed solely to help pedestrians cross busy roads, even though facilitating movement across roads is a secondary benefit they offer. A median may be considered as an extra-long pedestrian refuge—a safe staging post for pedestrians halfway across the road. Being able to

select a gap in one direction of traffic at a time greatly reduces pedestrian delays. For a median to serve as an effective refuge, it must be wide enough (at least 2 m, but more width is preferable). Vegetation or landscaping on the median should not obscure sight lines to and from pedestrians at critical locations.

241. Some useful tips for safe medians in *urban* areas are as follows:

- The median should be used to allow pedestrians to cross roads in stages at active crossings (POSSs, PUFFINs).
- Traffic should be stopped in one direction at a time, to minimize driver delay. This requires enough pedestrian storage space on the median.
- Sight lines should be kept open (commensurate with traffic speeds).
- An all-weather surface should be provided on the median, at known crossing points.
- A “cut-through” should be constructed at points in the median where groups of pedestrians cross (such as at bus stops and near markets). Cut-throughs at road level are helpful to all pedestrians, especially those on crutches and in wheelchairs.
- Streetlights should be used to illuminate these arterials. Additional lighting should be installed at all crossings, as well as in places along the road where groups of pedestrians cross.



Urban medians. Medians can be useful to pedestrians especially at locations where crossings would cause traffic congestion. In urban areas, they can act as long refuge islands, and in rural locations, they allow pedestrians to cross high-speed roads in stages. Sight lines should therefore be clear, and the median should be wide enough to provide adequate storage for the pedestrians waiting to cross the road. Cut-through paths ensure access for pedestrians with disabilities and help direct pedestrian traffic to crossing points (top left photo by Ministry of Transport, Tajikistan).

242. The following are useful tips for safe medians in high-speed *rural* areas:

- Sight lines should be kept open (vegetation should be pruned, commensurate with traffic speeds).
 - An all-weather surface should be provided on the median at known crossing points.
 - A cut-through should be constructed at points in the median where groups of pedestrians are known to cross (such as at bus stops). Cut-through paths can improve access for pedestrians, especially those on crutches and in wheelchairs.
 - Stagger pairs of bus stops, with a cut through in the median located behind each stop (to encourage passengers to walk behind their bus) (See section H).
 - Avoid placing unnecessary items (planter tubs, or statues) on a median where pedestrians will cross. They can block sight lines in addition to being roadside hazards.
- No crossing should be installed in high-speed rural areas. Any crossing that gives right-of-way to pedestrians in such locations is unsafe, regardless of the number of traffic lanes. Pedestrians should be assisted with safe storage on medians, but zebra crossings should *not* be installed in high-speed areas.

Engineers should remain open to the notion that, in some locations, pedestrians are safer without a formal crossing.



Rural medians. Both of these photos show roads for left-side driving. Medians can provide a useful and safe storage place for pedestrians in high-speed rural areas. For greater safety, good sight distance should be provided in places used most often by crossing pedestrians.

H. Bus stops

243. Good public transport is essential in all CAREC countries. Many pedestrians use *marshrutkas* (routed taxicabs), minibuses, or taxis daily to get to work or to go shopping. The provision of practical and safe bus stops is an important issue for them and for road safety overall. Bus stops should be spaced to suit the passengers. Some may be midblock, serving shops and markets, while others are at intersections, where they serve pedestrians from each direction.

244. All bus stops must be convenient, safe, and comfortable places for the customers to wait. This means that, at a minimum, there will be shelter (from rain, snow, and wind), a paved bus-boarding area, and an overhead light for personal security at night. Bus shelters are indispensable in most CAREC countries, but attention must be paid during design to ensuring that the shelter does not take up most of the footpath. Bus shelters must allow ease of movement along the footpath by all pedestrians, including those in wheelchairs and on crutches. Conspicuous advance warning and location signs, along with suitable all-weather footpaths leading to and from the stop, are also required for pedestrian comfort and safety.

245. Indented bays at bus stops assist with traffic flows but sometimes cause difficulties for bus drivers trying to rejoin the traffic stream. Other drivers are sometimes reluctant to let buses merge into the traffic stream from indented bus bays. Some countries have now removed indented bays from some roads,

including arterials, and buses now stop in the curbside lane. This practice can slow the traffic behind and is sometimes used as a traffic management control technique. A few countries have introduced road rules requiring drivers to give way to buses that are pulling out from an indented bus bay, but these rules must be enforced.

246. For the best level of service to customers, bus stops should be located at or close to a pedestrian facility. Passengers who travel one way in the morning will invariably travel in the opposite direction later in the day. On one of these trips, they will have to cross the road; a well-placed facility is the best way to induce them to use the facility. Just what the facility should be will depend on the class of road, the speed of traffic, the number and density of pedestrians, and some site-specific issues. All options—ranging from a pedestrian refuge island to a cut-through path on a median, to pedestrian-operated signals, to a PUFFIN crossing, or even to a pedestrian overpass in some extreme situations—are outlined in this manual.

247. If a bus stop is placed on the approach to a passive pedestrian facility (such as a zebra crossing) or an unsignalized intersection, pedestrians at the facility may not be able to see approaching vehicles. The drivers of those vehicles may also not see the pedestrians and may not be able to stop in time when a pedestrian steps beyond a stopped bus into their traffic lane. A safer option is to place bus stops on the departure side of passive crossings or intersections. In these locations, as a rule after alighting, passengers should walk behind the bus. Doing so minimizes the



Indented bus bays for safety. There are a multitude of types of bus stops across the CAREC road network. For safety, it is best to provide an indented bus bay in which buses can stop to pick up and set down passengers. Additional items like a shelter, lighting, footpaths, and signs should also be carefully considered.

risk that the bus driver may not see them as the bus starts up. It also reduces the risk that approaching drivers from the same direction may not see them because of the bus.

It is sometimes best for pedestrian safety to *not* give priority to the pedestrians, but to warn approaching drivers of their possible presence on the road.

248. A word of caution must be added at this point. If the bus stop is located in a rural area where the road has several lanes or speeds are high, it is unwise to install a zebra crossing or any other crossing, in the well-intentioned belief that it will help pedestrians cross the road. A zebra crossing (or a POS or other formal crossing) on a rural highway with high speeds will not help the pedestrians; it may even increase risk. A driver traveling at 100 km/h on the highway will be unlikely to stop and give way to a pedestrian who steps onto a crossing. The driver may not see the pedestrian in time, or the driver may be concerned about being struck from behind if the vehicle were to stop on the high-speed road. Whatever the reason, the pedestrian

gains nothing from a zebra crossing in these situations. Engineers should remain open to the notion that, in some locations, pedestrians are safer *without* a formal crossing.

I. Pedestrian fencing

249. Pedestrian fencing is used in specific locations to guide pedestrians to a useful pedestrian facility or to prevent them from walking innocently into a hazardous situation, such as a conflict with fast-moving traffic. Pedestrians will often attempt to use the shortest and most convenient path (their desire line), which can lead them into unsafe crossing situations. Pedestrian fencing, by adding a physical impediment, can make the hazardous situation less likely to occur, and in turn increases the desirability and convenience of the designated crossing points.

250. But too much fencing can be restrictive to pedestrians and to walking and active travel, as it causes pedestrians to make a long detour to cross a road that might be just 15–20 m wide. This is inconvenient for pedestrians, especially the elderly and the mobility-impaired. Some European cities, including London, are now removing pedestrian fencing from many roads as part of an overall strategy to enhance the livability of the urban environment. Early experience indicates that pedestrian safety also improves.



Pedestrian fencing. Pedestrian fencing can be useful in directing pedestrians to safe crossing points, or in preventing them from stepping innocently into high-speed traffic. Its design should not allow climbing, but it should offer good visibility through the upright bars. There is thus a better chance that a small child will be seen by drivers before darting onto the road.

251. Pedestrian fencing should not be installed unless it serves a necessary purpose, and should be adopted only after other solutions have been considered, such as relocating a crossing, improving footpaths, moving exposed people away from the hazard, or reducing the risk of the hazard. Five key questions should be asked when considering pedestrian fencing for a site:

- Is fencing really needed?
- Are there any alternatives?
- What is the purpose of this fencing?
- What type of fence should be used?
- Where will this fence be positioned?

252. Most pedestrian fencing is not designed to stop an errant vehicle and should not be used as an alternative to a safety barrier. However, some new types of “crashworthy” fencing are now available. This fencing is deemed crashworthy for a specific speed environment and may therefore be installed adjacent to traffic (on the verge and on medians). Crashworthy fencing may be used in areas where pedestrian volumes are generally higher, such as schools,

shopping centers, bus stops, and tram stops, and near intersections. Road authorities should contact major suppliers and get more information about how the “crashworthy” fencing works and where it may be installed.

253. Some useful safety tips to note during the design of new pedestrian fencing are as follows:

- Driver sight distance must be maintained at intersections, to crossings and through the inside of horizontal curves.
- Pedestrian (including child pedestrian) sight distance must also be maintained, especially on crossings and curves.
- The fencing design should discourage pedestrians from crossing or climbing, but it should not have any sharp elements where pedestrians could get snagged or injured.
- Fencing should typically be 1,200 mm high.
- It should be attractive and in a suitable color to suit municipal needs.
- Most fencing will not shield pedestrians from vehicle impact.

- Some new types of fencing are considered crashworthy and may stop small vehicles, but only at low or medium speeds. This fencing should not be used as an alternative to a correctly tested and installed safety barrier.
- A 0.3 m offset from the traffic lane should be provided (wider offsets, if possible, are preferred) to minimize nuisance hits, and to avoid the additional risks (snagging, scratching) arising from the continued use of damaged fencing.
- The risk of pedestrians being trapped on the road after attempting to cross it, or exiting a vehicle without noticing the fence, should be minimized.
- Parking requirements at the site (including loading zones, formal and informal drop-off and pickup areas) should be considered.
- Post and rail fencing (such as galvanized pipe and timber rails, or treated-pine post-and-rail fencing) with horizontal rails should not be used near roads, as the rails can spear errant vehicles.
- Components that can be dislodged and projected through the air upon vehicle impact should not be used.
- The fencing should be suited to the environment (snow, heat, wind), and should be sturdy and durable for the duration of its design life.

J. Threshold treatments

254. “Threshold treatment” is a generic term for civil works built around the perimeter of an area-wide traffic management scheme, usually in a busy urban area. It is the first device over or through which drivers pass as they enter the local area. The specific threshold treatment with positive benefits for pedestrians is a raised pedestrian footpath. It permits pedestrians walking along the main street to continue at the same level across a side street and onto the footpath beyond.



Reducing speeds in areas of conflict. Threshold treatments can look attractive, can provide a clear and well-defined entrance into a local area, and offer some practical benefits to pedestrians. A zebra marking may be installed across the hump if the national standards or road rules require such markings at intersections.

255. Threshold treatments create a physical road hump for traffic from the side street, causing it to slow down as it approaches the stop or the give way sign at the intersection. The road rules may or may not give pedestrians priority over the traffic, but the low speeds and the imminent intersection cause most drivers to negotiate right-of-way with pedestrians in a respectful manner.

256. The following are some useful tips for safe threshold treatments:

- Such treatments should be installed only across side streets that intersect with a higher classification of road.
- Grades onto the hump should be on the order of 1:12.
- The footpath along the main street should be continuous across the raised hump.
- Pavement texture and pavement coloring may be used to enhance the visibility of the threshold, and to aid urban aesthetics.
- If successive side streets are treated, a consistent style, pavement texture, or color can be adopted to enhance urban connectivity and aesthetics.
- Depending on the national road rules, pedestrians may not have legal priority over traffic (turning

or straight). Therefore, thresholds should be installed where drivers on the side road are likely to approach at low speed and are better prepared to yield to the pedestrians.

- Each threshold should be designed with good drainage. Any civil works will be unpopular if they trap water, snow, or ice.

K. Streetlighting

257. Many pedestrians, mistakenly believing that drivers can see them at night, sometimes behave in ways that put them in the path of an unknowing driver. Good streetlighting helps address this common mistake and gives drivers that added small amount of time needed to be able to stop. In addition, good-quality streetlighting improves urban environments as it increases pedestrian comfort and personal safety.

258. Streetlighting resources should first be directed to busier, higher-speed urban arterial roads. On local streets, where traffic calming is needed to maintain lower speeds, it is desirable to give priority to keeping all intersections and public transport stops well lighted. On all roads, pedestrian facilities such as



Illuminating the road. Good-quality streetlighting along both sides of arterial roads can assist the safety of pedestrians as well as other road users.



Illuminating the road. On roads through rural villages, consistently spaced lighting helps drivers see people and objects on the road. Good streetlighting is a key initiative to reduce collisions involving intoxicated pedestrians.

pedestrian crossings, POSs, and pedestrian refuges should have additional lighting. A lower level of lighting may be acceptable for pedestrian paths, such as those through parks and away from roads, but it must be adequate for personal safety.

259. Urban streetlighting programs should therefore seek to

- ensure that all points where pedestrians cross arterial roads receive a higher level of illumination (or even floodlighting);
- ensure that establishments that trade at night receive a higher level of illumination;
- provide high levels of lighting at pedestrian underpasses (subways);
- provide a uniform level of lighting elsewhere on the road network;
- illuminate pedestrian paths as well as roads and streets; and
- enhance the safety and security of busy commercial districts.

L. Bridging over drains

260. Many towns and cities in CAREC countries have open concrete drains between roads and footpaths. Such drains are reportedly favored because of their cost and ease of cleaning, but they present a longitudinal obstacle to pedestrians seeking access to a road or a parked vehicle. Some people slip and fall into these open drains and some vehicles end up in them because of incidents on the road.

261. If an open drain is in the way, a crossing will be less used. Some fit adults may jump these drains, but many small children, the disabled, and the elderly cannot do this. Often, they must walk out of their way to reach the road and cross it. Good urban design calls for a simple, level access between a footpath and a crossing point on the road, to serve all pedestrians. Therefore, one seemingly minor piece of civil works that is vital to pedestrian mobility is a bridge across these open drains.

262. The bridge must be wide enough to fully serve the adjoining crosswalk. This width is typically 2 m, allowing for a wheelchair user in one direction and an able-bodied pedestrian in the other. The bridge should be flat, or as flat as practical, so that wheelchair users can wait on it for a gap in traffic or for signals to change. Slopes are not easy for wheelchair users to negotiate. The bridge should be connected by an all-weather path to the footpath to give continuity to pedestrian movement.

263. As many of the larger cities and town across the CAREC region do not have enough bridges across open drains, inspecting the road network and establishing a program of works to construct bridges over drains where they are needed through the city or town can be a positive and low-cost initiative. Small bridges are needed over any open drain, but they are needed most to serve wheelchair users and other disabled groups. Any such annual program of constructing small new bridges should look to places used by the disabled and the elderly, as well as high-volume locations in busy shopping centers, at schools, hospitals, places of worship, and bus stops. Ideally, many of the open drains in the busiest areas can be changed to curb and channel drainage over time. Even small yearly changes will soon improve the urban ambience for the pedestrians.

264. When planning to place small bridges over drains, planners and engineers should try to make them

- wide enough for the expected volume of pedestrians;
- sufficiently wide to allow a wheelchair user and an able-bodied person to use the bridge at the same time (typically 2 m);
- aligned with any crossing on the road, as well as any bridge on the other side;
- smooth, with a slope of less than 1:12; and
- oriented at right angles to the road.



Hazards to road users. Open drains like these are roadside hazards and are not pedestrian-friendly. In city centers, many of these drains have been replaced by piped drainage systems, and these are the favored option. But in locations where such replacement will not happen for a long time, bridges across the open drains are necessary to assist pedestrians and to guide them toward crossing points. Bridges are essential for wheeled, mobility-impaired, and visually impaired pedestrians.

M. Improved skid resistance

265. Surface treatments involving hard, polish-resistant aggregates and resin-based binders can provide high levels of surface friction in critical locations such as intersections, tight curves, and approaches to pedestrian facilities. Calcined bauxite is commonly used to improve skid resistance. It is extremely wear-resistant, with a polished stone value (PSV) almost double that of aggregates from naturally occurring stone sources. The combination of resistance to embedment and resistance to wear results in the retention of good macrotexture over longer periods of time than those for normal asphalt surfaces.

266. Calcined bauxite surfacing treatments can provide high skid resistance and improved safety performance, but they are costly. These treatments can normally be economically justified only at sites with a high crash risk. Evaluations have shown a 20% reduction in collisions at critical locations with high-PSV overlays, and a 40% reduction in collisions on wet roads with such overlays. They should be applied only to sound pavements in good condition and should not be used on rutted or unstable asphalt, on ultrathin, open-graded asphalt, or on sprayed seals.

267. Skid-resistant overlays can improve pedestrian safety, especially when selectively applied on the approaches to pedestrian facilities. The priority

(whether at a new crossing or at an existing one) should always be ensuring that the crossing is conspicuous and that it conforms to all national requirements. Then it is important to be sure that sufficient warning signs and markings are in place, and that the streetlights are in good working order. After that, the engineer in charge of the project may consider applying a skid-resistant overlay for the last 50–75 m on each approach to the crossing to further improve safety.

N. Pedestrians at railway crossings

268. Where busy roads intersect busy railway lines, road traffic must be controlled to prevent serious collisions. Grade separation or active railway-level crossings (flashing signals, and booms or gates) are common forms of control. Pedestrians walking along these roads, or along the footpath beside the road, also need assistance in crossing the railway tracks safely. Multiple tracks, and high-speed trains, can magnify an already high-risk situation. Providing the following at railways can improve pedestrian safety:

- A smooth path, with no gaps between track and path, for all pedestrians but especially for disabled pedestrians. There have been cases where wheeled pedestrians have lost their lives when a wheel became stuck in a gap beside a rail track.

- Warning and regulatory signs, at pedestrian crossing points over single railway tracks where slow- or medium-speed trains pass, and where pedestrian volumes are low.
- Active controls will be needed at pedestrian crossing points over multiple rail tracks, particularly when pedestrian volumes or train speeds increase, to prevent pedestrians from entering the track area as a train approaches. A number of these active pedestrian crossing devices are available, at varying cost.
- Grade separation, at high-volume pedestrian crossings over multiple rail tracks used by high-speed trains, with an overpass over the tracks or an underpass underneath. It is highly dangerous to allow pedestrians to negotiate multiple tracks and/or high-speed trains at track level.



Assisting pedestrians at railway crossings. These photos show a set of active pedestrian gates at a crossing over two tracks. The gates close automatically when a train approaches. An audible beeper alerts approaching pedestrians for 5 seconds before the gate begins to close. The pneumatically operated steel gates prevent access, but there is a lightweight emergency gate that someone trapped on the track side of the gate can open to exit the tracks.

VII. Traffic Calming

269. There are many health and environmental benefits from walking, and urban renewal in many cities is now providing spaces where people can walk and enjoy the experience. Low-speed environments (30 km/h or less) have been shown to be amenable to safe pedestrian and vehicle interaction; these low-speed environments are proving to be essential components of successfully planned urban areas.

270. The Dutch concept of “sustainable safety” has the aim of reducing crash risk through infrastructure design, particularly by making a distinction between road functions, separating travel modes, and reducing vehicle speeds in areas where vulnerable road users and vehicles mix. It demonstrates that managing speed is an essential element of improving safety, especially for pedestrians:

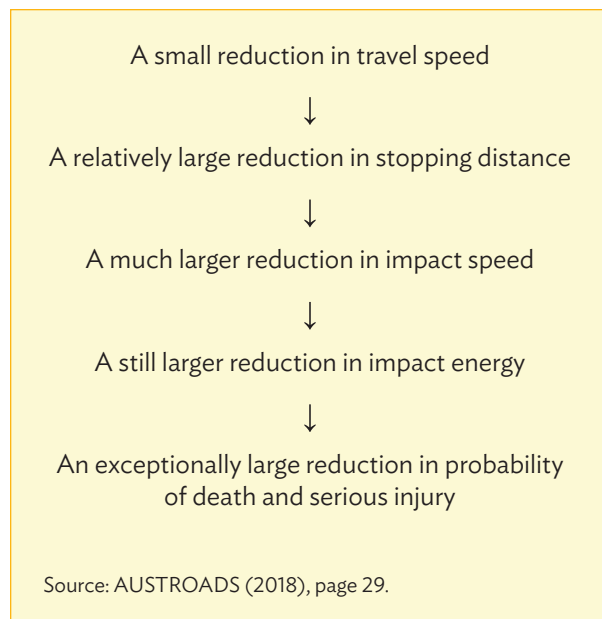

271. Under the Safe System, 30 km/h is the maximum safe speed for situations where pedestrians interact with motor vehicles. Careful design of infrastructure should ensure that motor vehicles are restrained to speeds of 30 km/h or less when they are in areas commonly used by pedestrians. Designs should include physical infrastructure as well as regulatory signs and other traffic

management devices, as experience shows that the use of speed restriction signs alone is unlikely to reduce operating speeds unless there is an ongoing police presence. Such enforcement is difficult to maintain. However, a more sustainable option is to change the street environment so that the road itself helps contain vehicle speeds. Traffic calming involves the use of devices that make drivers and passengers feel uncomfortable if they travel along the calmed street at speeds higher than the intended speed. Traffic calming is a key tool used to combat speeding and other unsafe driving behaviors in local streets. Its aim is to encourage safer, more responsible driving, lower operating speeds, and reduced traffic flows (particularly unnecessary through traffic).

272. Each traffic-calming scheme should be planned, designed, and installed to suit the local conditions. It is unrealistic (and potentially a little unsafe) for an adventurous traffic-calming scheme to be the first one introduced in a city or a country with no experience with such treatments. In such contexts, it is advisable to commence traffic calming by treating low-risk streets with reasonably conservative (not too radical) treatments and a mix of various devices. By monitoring the performance of the devices used in

Figure 18: The Involvement of Speed in Pedestrian Collisions

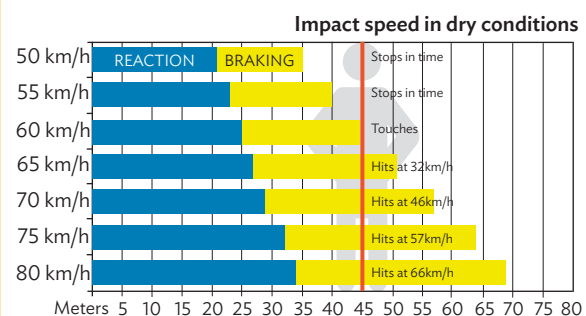

km/h = kilometer per hour.

Source: Transport Accident Commission website <https://www.tac.vic.gov.au/road-safety/statistics/summaries/speed-statistics>.



Vertical displacement devices. Vertical displacement devices reduce 85th-percentile speeds to about 35 km/h. Placing a crossing on top of a hump will make the crossing more conspicuous, and will enable pedestrians to cross at the footpath level (above any puddles), at the point where speeds are lowest. Placing a crossing on a road hump has been shown to reduce pedestrian collisions by 73% (Appendix 2).

this first scheme, the road authority can modify and refine the devices to be used elsewhere in the city.

273. The key message of this chapter is that effective traffic calming of local streets will curb through traffic, reduce speeds, create a safer road environment for all users, and improve the local environment. Pedestrians (young, old, disabled, intoxicated, and all others) benefit greatly from traffic-calmed local streets.

A. Traffic-calming devices

274. There are many proven traffic-calming devices available for engineers and planners to use. These vary in cost, and in their impact on traffic speeds and volumes. Some are more aesthetically pleasing than others, and some are preferred to others by residents. Traffic-calming devices are classified into several general groups.

1. Vertical displacement devices

275. Raising a portion of a street (with a hump or a raised intersection) can create discomfort for drivers traveling at high speeds. Both the height of the hump and the slope of the approach and departure ramps affect the severity of vehicle displacement. Placing a pedestrian facility on a road hump has been shown to reduce pedestrian collisions by 73% (Appendix 2). Vertical displacement devices include the following:

- Road humps (several profiles), each of which can reduce operating speeds to around 35 km/h.
- Speed cushions. These are two or three small humps in a line across the road that will slow cars but allow wider emergency vehicles to straddle them (and thus minimize emergency response time).
- Raised intersections, which lower vehicle speeds at the point of conflict.



Horizontal displacement devices. Horizontal displacement devices can be effective elements of traffic-calming schemes. These can be combined with road humps, colored pavements, and narrowings to control speeds and through traffic volumes on local streets.

- Raised crossings, which act as road humps for vehicles while helping pedestrians cross the road at the footpath level.

2. Horizontal displacement devices

276. Horizontal displacement devices require drivers to maneuver around them to pass along a calmed street or through a calmed area. The horizontal movement these devices create causes drivers to slow down, although usually not as much as vertical displacement devices do. This is because these devices must allow enough lane width for garbage trucks and delivery vans to pass through, and this same width can allow easy passage by small, fast cars. But despite this limitation, horizontal displacement devices do perform well as part of a traffic-calmed street, and they do offer opportunities for street beautification as well as areas that can serve as

pedestrian refuges. Typical horizontal displacement devices include the following:

- chicanes;
- pedestrian refuges and chokers;
- local street roundabouts, which require drivers to give way on entry and to pass around the central island; and
- curb extensions and offset curb extensions.

Effective traffic calming of local streets lowers speeds, reduces through traffic, and creates a safer road environment for all.

3. Street narrowings

277. Traffic lanes can be narrowed so that slower travel speeds seem more natural to drivers. Street narrowings can be less intrusive than other calming devices and include the following types:

- Lane narrowings created by widening footpaths, adding planters, adding a bicycle lane, or allowing on-street parking, to bring lane widths down to 2.5 m.
- Curb extensions that narrow the roadway (sometimes at pedestrian crossings, sometimes not).
- Curb extensions that narrow the street to a single lane. These must be marked with right-of-way signs.
- “Road diets,” involving the removal of a lane from a street (for example, allowing parking on one or both sides of a street to reduce the number of traffic lanes).
- Pedestrian refuges in the middle of the street.



- One-way streets converted into two-way streets so opposing vehicles are closer together. This, in turn requires more cautious, and usually slower, driving.

4. Gateways and traffic-calmed villages

278. Traffic calming of villages is important across the CAREC road network and is gaining support and interest. Where a highway or a major road approaches a village, drivers should be informed of the village ahead, and required to slow down. It is incredibly unsafe, especially for the residents of the village, when drivers pass through at full highway speed. Current road safety experience indicates that a pedestrian collision involving an impact speed of 50 km/h or more has a 55% risk of a fatal outcome. Slowing highway traffic in villages is therefore an essential task for national road safety engineers.

Traffic calming. Effective traffic-calming schemes include a well-considered mix of narrowings, road humps, color, pavement textures, and various forms of horizontal displacement devices. Residents welcome attractive, well-finished schemes that are nice to look at and make the area safer for themselves and their families.



Gateways. Each of these photos shows roads for left-hand driving. Perceptual line markings can affect drivers as they approach a village where they will be required to slow down. The “dragon’s-teeth” markings affect drivers through their peripheral vision, causing them to reduce speed. The gateway signs and colored pavement welcome the driver, impose a reduced speed limit, and one then asks the driver, “How fast are you driving?”

279. Approaching a village, perceptual line markings (such as dragon’s-teeth markings) can be installed along the sides of the approach lane for a length of 50–100m. These markings alert drivers that they are approaching a built-up area where they will be expected to reduce speed and (maybe) yield to other road users. At the entrance to the village, a gateway is often used as a favored way of informing drivers that they are entering a lower-speed section of the highway, where they will be required to drive much more slowly than in the rural parts of the highway. A gateway sign usually displays the name of the village as well as a regulatory speed limit, and often a warning sign or other safety message. The gateway may also have integrated features or markings on the road to make drivers clearly aware of the start of the built-up section. These features may include colored pavement markings, perceptual line markings, or other symbols. Sometimes



The road pavement. Changing the paving material or the color of the pavement changes the appearance of the street and can affect driver behavior.

a gantry can be used to alter drivers' perceptions of the road ahead, together with Slow markings or other warning signs such as Pedestrians, Children, or Hospital.

280. After the gateway, and as drivers become accustomed to the lower speed limit, it is usually necessary to install a series of traffic-calming devices to manage the lower speeds. Many CAREC highways have high traffic speeds but quite low traffic volumes; this combination lends itself to traffic calming in the villages these highways pass through.

281. When designing such traffic-calming devices, planners and engineers must remember to start with changed markings and signs outside the village before gradually introducing more substantial devices inside the village after the gateway. While some road authorities are reluctant to install road humps on highways, these are the most effective traffic-calming device. Humps, on any roads, must have the correct signs and line markings, must be well maintained, and should have overhead streetlights. With these provisos, professionally designed road humps are a recommended traffic-calming device for use inside traffic-calmed villages.



The road pavement. In changing the paving material, care must be exercise to make sure that the surface is not slippery in wet or icy weather, that it is suitable for bicyclists, and that it does not create too much tire noise to disturb residents.

5. Pavement changes

282. Changes in the texture of the road surface or its color can call the drivers' attention to the fact that they are in a pedestrian zone or a traffic-calmed section of road. Such changes include the following:

- a different surface material or texture (for example brick, cobblestone, or a thermoplastic or polymer overlay) to alter the visual appearance of the street; or
- rough pavements that produce tire noise or vibration to deter higher speeds.

6. Restrictions on movements

283. Traffic may be fully blocked or partly restricted by several types of restriction devices. With fewer

vehicles passing along a street there is less exposure to risk for pedestrians. This is further enhanced when the remaining vehicles are calmed down to speeds of 30–40 km/h. Access can be blocked or restricted by means of the following:

- median diverters on arterials, to prevent turns into a residential street;
- bans on turns (usually from an arterial road into a local street);
- street “throttles,” with or without one-way access;
- conversion of an intersection into a cul-de-sac (dead end);
- a boom barrier or bollards to restrict traffic to authorized vehicles; or
- full or partial street closures.



“Throttles”. Street “throttles” can be applied in midblock locations or at intersections. Some may have one-way signs installed, while others rely on opposing drivers seeing each other and giving way in a spirit of cooperation. Pneumatic bollards keep unauthorized vehicles out of calmed streets.

B. Advantages of traffic calming

284. Traffic calming helps improve urban environments besides slowing traffic and improving road safety. Its benefits can be summarized as follows:

- Collisions (particularly those involving pedestrians) are less common and less severe.
- Crash reduction factors of between 50% and 65% have been reported for pedestrian collisions (Appendix 2).
- Lower speeds give drivers more time to react to unexpected events and avoid them.
- Increased journey times discourage drivers from entering traffic-calmed streets unless they need to be there.
- Decreased vehicle speeds lead to improved environments, with less neighborhood severance.
- Streetscapes become more attractive as landscaping and paving designs mature.
- Traffic-calming devices can be used on existing roads or new roads.

C. Disadvantages of traffic calming

285. Good traffic calming requires good design and adequate resources. It is not expensive (certainly not when compared with the costs of new roads and interchanges), but it does need sufficient funds to look good as well as to perform as intended. Like all

infrastructure, it also needs ongoing maintenance. The following are commonly reported disadvantages of traffic calming:

- Large vehicles are generally slowed down more than cars or motorcycles, and may find some maneuvers difficult. This can create problems for bus operators, emergency services, and garbage collectors.
- Noise levels and vehicle emissions may increase if vehicles speed up between devices. Spacing the devices closely enough (but not too close) is an important design element to minimize this effect.
- Additional maintenance may be required, as traffic can damage some devices. Residents expect to see and enjoy a well-maintained, improved streetscape.
- Adjoining “non-calmed” streets may encounter an increase in traffic volumes (diverted from the calmed street) that can upset residents. Careful planning can minimize such impacts.

286. There are many useful texts and websites that discuss traffic calming. Interested readers are directed to these sources for more information about this emerging field.

D. Shared zones

287. A shared zone is a road or street (or a network of roads or streets) where the road space is shared by vehicles and pedestrians. There are usually no line



Pedestrian zones. Shared zones are supported by national road rules that give pedestrians priority over motor vehicles.

markings or curbing in a shared zone, to show that pedestrians and vehicles are equal. A shared zone is defined with a regulatory sign at its start and another regulatory sign at its end. In a shared zone, drivers must give way to pedestrians at all times, and they are restricted to the speed limit (usually 10 km/h or 20 km/h) shown on the regulatory sign. The shared-zone concept must be supported by national road rules, which may also define other limitations such as restricting parking to a marked bay (elsewhere in

the road network, drivers may park anywhere except where parking is prohibited).

288. Most shared zones are in commercial areas, where they improve foot traffic past shops and businesses, but some are also in residential streets. These zones tend to be relatively short (up to a few hundred meters maximum), but they do create pedestrian-friendly areas where pedestrians can feel comfortable.



Shared zones. National road rules usually include a low speed limit, and restrictions on parking, except in marked bays. Shared zones are especially useful in commercial areas with heavy volumes of pedestrians but modest vehicle volumes.

VIII. Case Studies

289. Seven case studies are outlined in this chapter. They have been prepared by the ADB road safety engineering consultant based on his experience in the CAREC region and are a mixture of real and theoretical pedestrian safety problems. Details for some sites are based on local data, while for others the case study features assumptions and estimates. Some of the case studies are known problem sites that have been recently investigated; others are locations that are representative of a problem for one (or more) group of pedestrians. The case studies have been selected to demonstrate typical pedestrian issues on different classes of roads, and to show how engineers can put into practice some of the processes and strategic issues detailed earlier in this manual. The case studies hold several key messages—the

importance of detailed crash data, the value of cooperation between key stakeholders, and the need to focus closely on the safety needs of pedestrians. CAREC roads will become safer as engineers work to provide pedestrians with the facilities that will serve them best.

A. Case study 1

Pedestrians crossing a busy divided arterial road to get to and from a new hospital

290. A major hospital has been constructed beside a wide divided arterial road. The road is flat and straight, with three lanes in each direction plus parking, bus



“Before” photographs of the site outside the new hospital. Pedestrians use an arterial road that may need further safety improvements (bottom right photo by Matthew Chamberlain).

stops, and a 15-m-wide central median. It carries more than 20,000 vehicles per day (vpd) with speeds of around 60 km/h. The nearest traffic signal-controlled intersections are 300 m south, and 700 m north, of the hospital entrance.

291. An average of 2,500 pedestrians cross the road each day to visit or work in the hospital. Concerns have been expressed by hospital officials and police about the lack of a pedestrian facility to assist pedestrians in crossing this busy road.

1. Safety issues

292. About 400 pedestrians per hour cross the road in the busiest times. Most pedestrians are adults, but they include family groups, some disabled persons, and many senior citizens. The potential for high traffic speeds, the width of each part of this divided arterial road, and an absence of any pedestrian device here presents a high risk to the safety of the pedestrians. Requests have been made by several groups for a pedestrian overpass, a zebra crossing, and a lower speed limit. While such options could help reduce the risks to some pedestrians here, none of them alone will eliminate this safety concern.

2. Considerations

293. Grade separation (an overpass or an underpass) is ruled out because

- high-voltage pylons on the median will require relocation if an overpass is built, while underground services in the median will require relocation before a subway can be constructed, and both will incur high costs; and
- many of the pedestrians are elderly—some are in wheelchairs—and will find it difficult to go up and down steps to reach a footbridge or subway. Ramps could be designed, but these would take up a large part of the footpath outside the hospital.

294. Curb extensions (spatial separation) can improve sight lines by placing waiting pedestrians just beyond the parked vehicles. But curb extensions alone will not help gap acceptance in the heavy traffic flows. Temporal (time) separation is necessary, to provide pedestrians with safe gaps in the traffic. Options in this category include a zebra crossing, a fixed-time midblock set of pedestrian signals, a set of POSs, and a PUFFIN crossing.

295. A zebra crossing is not suitable for this divided road, as it has three lanes in each direction (zebra crossings on such wide roads are high-risk facilities). Fixed-time traffic signals or POSs (with push buttons) could serve pedestrians satisfactorily, provided that the walk time and the clearance times are adequate. But in view of the high proportion of young, elderly, and disabled pedestrians at this site, a pair of PUFFIN crossings is considered the option that will give the best service to all. PUFFIN crossings, with their overhead detectors, will be able to increase the clearance time as necessary for slow-moving pedestrians.

3. The agreed decisions

296. It is decided to install Pedestrian Operated Signals (POSs) across both parts of this divided arterial road. Each will have pedestrian push buttons and, in time, overhead detectors will be added to increase the clearance time when slow-moving pedestrians (seniors or disabled) are detected.

297. Generous curb extensions will be constructed in the parking lanes to help waiting pedestrians see and be seen. The signal pedestals will be placed on these curb extensions to maximize their conspicuity (there are large street trees nearby). Two new streetlights will be installed at the crossings to illuminate pedestrians for approaching motorists.

298. A 3-m-wide concrete path on the median, will link the two crossings. Warning signs and new line markings will be installed. The traffic police, involved throughout the decision-making process, have agreed to assist with parking and speeding enforcement in this area.

299. The crossings will become PUFFIN crossings when the overhead detectors are installed, and they will be the first of their type in this country. The road authority is making special efforts to ensure that it has appropriately trained technicians available to assist with the installation, and with needed maintenance or repairs.

4. The result

300. The crossings were installed and are reportedly working well. The pedestrians have quickly learned to press the button and wait for their walk signal. The new pair of crossings are shown in the photograph. Curb extensions have not been constructed yet, and a decision about these will be made in the near future after monitoring of the crossings is complete.



“After” photographs showing the newly installed pedestrian operated signals. The pedestrian operated signals are serving the pedestrians well. The curb ramps and the small bridge over the drain give the pedestrians easy access to the crossing, and the push buttons allow them to call up their walk signal (photo credit: Eastern Alliance for Safe and Sustainable Transport [EASST], the Young Generation of Tajikistan, and the Safer Roads Foundation).

B. Case study 2

Schoolchildren walking along a highway to school

301. A district school serves a village and the surrounding area. It is located on the western edge of the village, beside a national highway. Most of the students (aged 5–14 years) walk along the highway from the village to the school, and a few catch a bus from outside the school to their homes further away. The highway has one lane in each direction plus unsealed shoulders. The speed limit is 60 km/h (because of the settlement), but there are no speed restriction signs and some drivers travel faster, even when children are near. There are no footpaths outside the village.

1. Safety issues

302. The school is the only school in the district and was built when motor vehicles were less common than they are today, and before the safety of young

pedestrians on the roads became such an issue. Most of the students walk to and from school with friends, but some of the younger ones are accompanied by parents or an elderly relative. In winter, the walk home is often made in the dark.

303. After two pedestrian collisions and several “near misses,” the parents seek action from the road authority. They request improvements such as a footpath, a lower speed limit on the highway, and a zebra crossing to get to the bus stop.

2. Considerations

304. The road authority sends two engineers to inspect the site, meet with stakeholders, and prepare a list of practical treatments to help school-age pedestrians walk safely between the village and the school. The engineers make sure that their inspection takes place on a school day, and they wait at the school gate for the first students to arrive. They observe that the students are well behaved, and that



“Before.” Photographs of the road and the area between the village and the school.

they walk along the unpaved shoulder and tend to walk in small groups. They notice that some students approach the school from the other direction (away from the village) and that several children get off a minibus at the stop on the other side of the highway. They observe a young woman assisting groups of students to cross the highway by waving a red flag to approaching drivers. They note that the highway is straight and flat. The road reserve is wide, and the fence line is set well back from the road. There is good visibility along the highway, as the vegetation (mainly small trees) is set well back. Traffic speeds are above the 60 km/h speed limit, but traffic volumes are low. There are no signs to warn drivers of the presence of the school or the bus stop ahead, or to remind them of the speed limit. The centerline of the road is worn out and only a few sections of edge lines remain.

305. It is a bright sunny morning, and the engineers ask some students and parents where they walk when it is snowing or wet. They learn that the students walk along the road when there are no vehicles coming (because the road is smooth and dry), but they step onto the muddy shoulder when necessary. In discussions with the head teacher, they learn that half of the students walk from the village (about 450 m away), about a quarter of the students walk from the other direction (various distances, up to 1 km), and the rest catch a minibus.

306. The engineers consider the segregation–separation–integration strategy for pedestrian safety and decide to explore integration options:

- For pedestrians walking along the highway they could pave the shoulders, or they could construct an all-weather off-road footpath.
- For students crossing the road to or from the bus stop, they could construct a refuge island or install a zebra crossing. POSs and a pedestrian overpass are not considered because of their high cost, the limited numbers of pedestrians who need to cross the highway and the short periods of daily use.
- In each case, it is considered essential to manage vehicle speeds. Will speed restriction signs and police enforcement be adequate or are road humps needed?
- The engineers prepare a report and submit it to the road authority for approval.

3. The agreed decisions

307. The road authority wants to be proactive. It certainly does not want to wait until a more serious

pedestrian collision takes place, and it quickly approves a package of low-cost improvements that includes the following:

- a compacted gravel footpath (2 m wide and about 450 m long) along the fence line (behind the small trees) from the village to the school gate;
- new School warning signs (on each side of the highway), installed 100 m from the school in both directions;
- repeater 60 km/h speed restriction signs placed along this section of the highway and ending about 200 m further west of the school; and
- paving of the shoulder outside the school, and construction of curb extensions to reduce the width for pedestrians to cross between the bus stops.

308. No crossing is approved for this location, as the road authority does not believe that drivers will respect a crossing that is used for just a few minutes on school days. They discuss the desirability of a new type of “part-time” crossing but decide to raise this as a national issue rather than install a new type of crossing, which will initially be unusual to drivers, in isolation here.

309. They also discuss a lower speed limit for school times, knowing that speeds of 30 km/h or less are necessary for pedestrian safety under the Safe System. This is not approved at this time, pending further discussions at the national level about school speed limits. Road humps are also not approved at this time.

4. The result

310. The road authority has built the off-road footpath, and the students enjoy it as they walk to and from their school. The shoulder paving and the curb extension are being designed. The road authority has installed the new signs (School warning signs and 60 km/h reminder speed limit signs) and new line marking (centerline and edge lines) as recommended by its engineers. It is acknowledged that the 60 km/h speed limit is too high for times when children are walking along the road, but the signs do help to remind drivers of the speed limit and they help police with enforcement. Meanwhile, the road authority is developing a national policy for school speed zones, and it is expected that this location will be one of the first to receive a lower speed limit during school times.



“After” photograph of the new footpath. The footpath offers pedestrians a safe attractive alternative to walking along the road between the village and the school. It is an all-weather path that can be used even in wet and snowy weather. The nearby trees offer nice shade on hot days.

C. Case study 3

A pedestrian blackspot at a zebra crossing

311. A zebra crossing lies across a wide urban arterial road, six lanes wide. The road is flat and straight, with parking along both sides, and bus stops on the approach to the crossing. The roadside is cluttered on both sides of the road with advertising signs, parked vehicles, shelters, and trees.

312. Police report that 11 pedestrians were fatally injured last year in collisions at this crossing, and 15 others were severely injured. The police can report only that the people struck were adults who were crossing at or near the crossing after dark. No other details are known.

1. Safety issues

313. In the absence of more complete crash data, the road authority engineers must therefore make some educated judgments about what may be causing these crashes and what can be done to reduce them in the future. There is continuous development along the road (houses, shops, markets, service stations), but there are very few pedestrian facilities. There are just two intersection signals (without pedestrian signals) and three pedestrian (zebra) crossings along about 5 km of road. The pedestrians who cross this road are mostly adults and students walking to and from bus stops; the only child pedestrians observed are in the care of adults and seniors.



“Before.” Photographs of the blackspot at the zebra crossing that extends across 6 traffic lanes.

314. This crossing had safety problems several years ago and the road authority then added flashing yellow signals to the regulatory crossing signs to improve conspicuity. The local authority also installed streetlights (on the western side of the road only), but neither improvement proved fully successful. Another section of this arterial road, about 10 km further out of the city, is being duplicated at present, but funds for upgrading or duplicating the section of road at this crossing are unlikely to be available for some years.

2. Considerations

315. The engineers inspect the site and put themselves “in the shoes of the pedestrians” at the site. They drive up and down the road several times, day and night, and they walk across the crossing many times, day and night. Despite flashing yellow signals on the regulatory pedestrian crossing signs, they find the crossing is almost invisible to approaching drivers, day and night. The flashing signals have a slow flash rate and can be missed among the roadside clutter. The crossing markings are in poor condition, and the lane lines and centerline are worn out.

316. They notice the reluctance of drivers to give way to pedestrians on the crossing, and they see some pedestrians standing in the center of the road to avoid conflict with vehicles approaching quite fast. They observe that the crossing is dark at night, as several streetlights are not working. There is no floodlighting at the crossing.

317. The engineers develop four potential options:

- Retain the existing zebra crossing and bring it back to better working condition with new lines and better signage (*low-cost option*).
- Retain the existing arrangements and the zebra crossing and construct a pedestrian refuge in the center of the road to allow pedestrians to select gaps in one direction of traffic at a time (*low- to medium-cost option*).
- Construct a pedestrian overpass (*high-cost option*). This will have to span more than six traffic lanes without a central pier. Other local overpasses in this city are not well used, and there are concerns that an overpass here would similarly be little used.
- Construct a central refuge island and curbside extensions, retain three traffic lanes in each direction (the road has enough width if the parking is managed), and install a set of POSs (*medium- to high-cost option*). With correct

phasing, pedestrians can wait on the refuge island and cross one direction of traffic at a time. POSs are active crossings that give positive direction to drivers and take away their discretion about giving way. The POSs will assist the pedestrians with time separation (creating gaps in heavy traffic) and, with careful design, this arrangement can be matched into the duplicated cross section when this part of the road is upgraded (maybe in 8–10 years).

3. The agreed decisions

318. Zebra crossings should not be installed on any road (divided or undivided) with more than one lane in each direction. The old zebra crossing on this arterial road, which extends over six lanes of undivided highway, has been a high-risk location for a long time; retaining it is unacceptable, with or without a central pedestrian refuge island. A concern about the possible under usage of a pedestrian footbridge at this location then leads the engineers to recommend their fourth option—a set of POSs to replace the existing zebra crossing.

319. It is also considered necessary for a section of highway about 200 m in length to be duplicated to create a pedestrian refuge along the centerline of this six-lane road. Curbing will be installed along both sides of the road to formalize the parking and the bus stops, and to allow curb extensions to be constructed. POSs will replace the zebra crossing. The POSs will have at least one signal mast arm for each direction of travel, in addition to the other signal pedestals, to ensure that the signals can be seen amid the traffic. Two floodlights will be added to directly illuminate the crossing.

4. The result

320. The road authority has begun the design work for the new refuge, the curbing and curb extensions, and the installation of the new POSs. Knowing that this will take up to a year, and noting the high number of fatalities at this crossing, the road authority immediately acts to install two new floodlights at the crossing, to install new oversized Pedestrian Crossing warning signs and to renew the line marking (centerline and edge lines) at this location. The traffic police respond to the safety issue by increasing their enforcement of drivers using this road, focusing on speeding, drink driving and failing to give way at the zebra crossing.

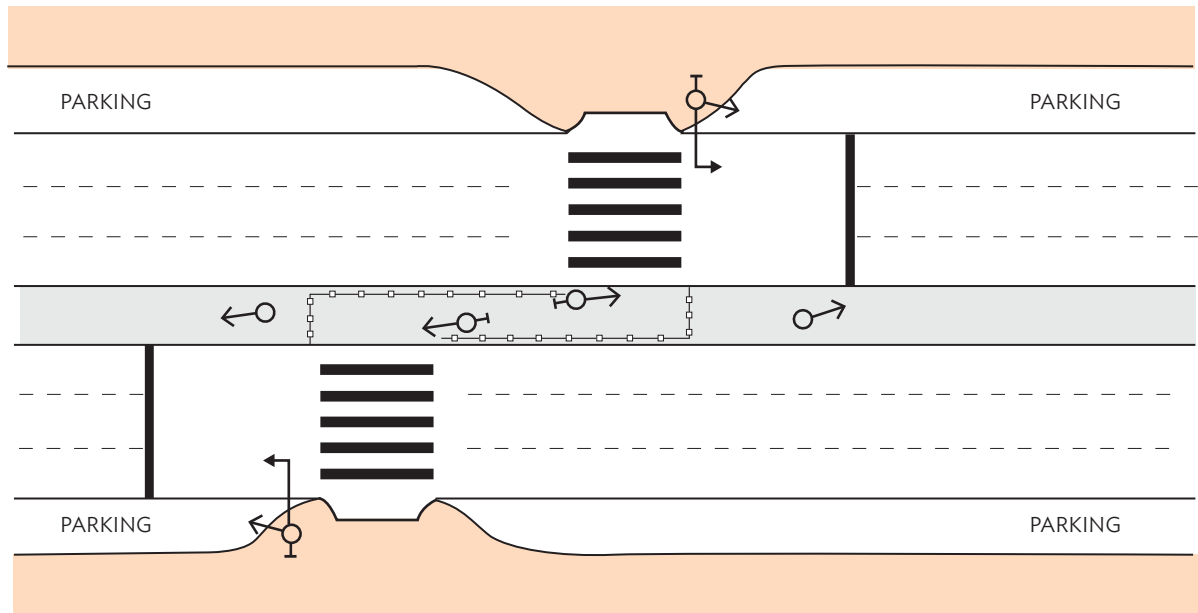
Figure 19: Case Study 3

The old zebra crossing is a dangerous crossing. Replacing it with an active form of time separation device will give positive instruction to drivers about when they must stop. By constructing a median, additional signals can be installed, and the two crossings can be timed to stop traffic in one direction at a time. This will reduce driver delays. The new floodlighting is already helping to improve the conspicuity of pedestrians in this vicinity.

Source: ADB road safety engineering consultant.

D. Case study 4

A pedestrian hotspot

321. A section of urban arterial road has experienced 12 pedestrian collisions in the past 3 years, mostly at night and in the morning peak time. The road has six traffic lanes plus two bus lanes; it is straight and flat, and speeds are often above the 60 km/h speed limit, particularly at night. Fixed-time intersection traffic signals are some 600 m away in both directions, but these have no pedestrian signals. There is a large pedestrian subway in this vicinity and authorities are dismayed that pedestrian crashes happen while this facility is so close.

1. Safety issues

322. The area beside the arterial road contains several multistory commercial buildings, a university, and a large park. The pedestrians who cross this road are mostly young adults (students and office workers), but there are also some middle-aged and elderly pedestrians who cross to bus stops. About 100 pedestrians cross the road each hour, selecting gaps in the six lanes of traffic. Often they wait on the centerline before crossing the second half of the road. Less than 50 people per hour use the underpass. The underpass is wide, quite open, clean, and reasonably well maintained. There are no shops or attendants



“Before.” The pedestrian hotspot is on a wide arterial road, close to a pedestrian underpass.

in it, and the lighting is poor. Pedestrians have to use steps to access the underpass on the north side, but the other end of it exits directly into the park.

323. Because of the serious collisions, the community has been requesting action. Some groups ask for the construction of a new pedestrian overpass or underpass (in a different location), while others want a zebra crossing, and a lower speed limit. While such options could reduce the risks at this site, none of them alone will be adequate to eliminate this safety concern.

2. Considerations

324. The existing grade separation (the underpass) is used by few pedestrians, despite being wide and clean. The underpass serves the park well but it is located east of where most pedestrians want to cross the road. Will renovating the underpass, and improving its lighting attract enough pedestrians to use it to, address the pedestrian safety problem? Or will the pedestrian collisions, especially after dark, continue? Will it be necessary to use fencing to restrict pedestrians from crossing at road level, and direct them into the underpass?

325. Spatial separation (a central pedestrian refuge) can provide a staging point for crossing pedestrians but will not assist with gap acceptance, especially when speeds are high. Curb extensions are not feasible in this section of road because of the curbside bus lanes. Temporal separation is therefore essential for pedestrians to have their own time to cross. The road authority is also anxious to keep traffic delays on this arterial road to a minimum. Options include a pedestrian (zebra) crossing, fixed-time pedestrian signals, POSs, or a PUFFIN crossing.

- Installing a pedestrian (zebra) crossing across six lanes of traffic is highly undesirable for safety. This option is not recommended.
- Fixed-time pedestrian signals could work, but they will delay traffic for a considerable time. Late at night, when there may be no pedestrians wishing to cross, a red signal will be ignored by many drivers. More efficient signal options are available.
- POSs will delay traffic for about 38 seconds each cycle, allowing for a walking speed and a clearance speed of 1.2 m/sec. Constructing a pedestrian refuge is therefore desirable, to provide a two-stage operation for the signals and to reduce vehicle delays. Such a refuge will have to be large enough to store the expected number of pedestrians.

- A PUFFIN crossing will further reduce delays to the motor vehicles but will also need a refuge island to be fully effective.
- Additional streetlights are desirable, regardless of the final decision about how best to assist pedestrians with time separation, as the present lighting is inadequate for this arterial route.

3. The agreed decisions

326. It is decided to take a two-stage approach to reduce this safety problem. Stage One will commence as soon as approvals and funding will permit, while Stage Two will require time for design as well as additional funding. The second stage will take place in the following year.

Stage One:

- Improve the underpass by constructing a ramp at the northern end (for the disabled) and by improving the lighting (outside and inside the underpass).
- Construct a long central refuge, where pedestrians can cross the road between the bus stops. A 2-m-wide refuge is achievable by reducing each traffic lane to a uniform width of 3.5 m. A 20-m-long refuge will be able to store 400+ pedestrians per hour.
- Install 12 new streetlights to enhance the area after dark.
- Begin regular police enforcement of speeding.
- Monitor the location closely after these works to assess if Stage Two is needed.

Stage Two:

- A PUFFIN crossing will be designed and installed in year 2 (when more funds are available), to give pedestrians the time separation from motor vehicles they need to safely cross this wide arterial road.

4. The result

327. The pedestrian underpass has been improved with a new ramp for disabled users at the northern end, and better lighting. A pedestrian refuge has been built in a location that serves two bus stops. It is being well used, and it is tending to focus pedestrians to cross at it, rather than randomly along the road. Most importantly, the new streetlights have made a big improvement to the nighttime conspicuity of the

pedestrians who cross the road. These improvements are working so well that the funding for the proposed PUFFIN crossing has been reallocated to another worthy location where it will be used for a new PUFFIN to replace an existing zebra crossing on

a wide arterial road near a large school. The road authority continues to monitor its road network and intends to upgrade many more pedestrian facilities across the city via annual works programs.

Figure 20: Case Study 4

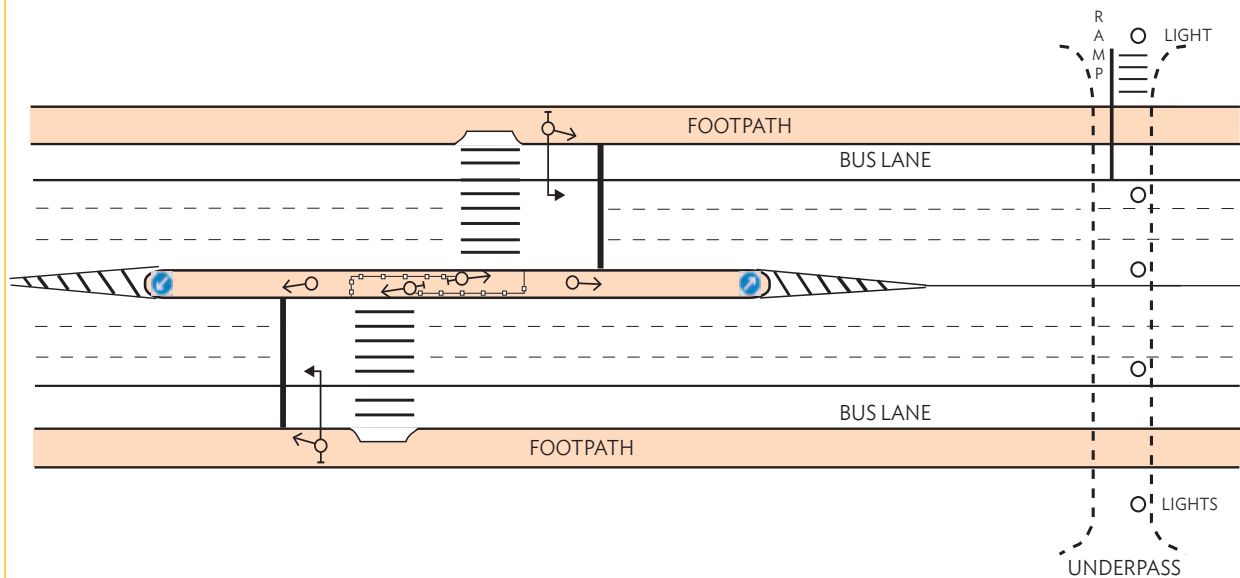

The large pedestrian refuge will help pedestrians who chose to cross this wide road at road level. Pedestrian refuges are useful and safe devices. They give pedestrians spatial separation, making their crossing movements safer and reducing their delays. However, at this location the traffic volumes are too high to permit the pedestrians to select suitable gaps, and therefore the pedestrian operated signals are necessary to create time separation for them.

Source: ADB road safety engineering consultant.

E. Case study 5

A national program of civil works to assist pedestrians

328. A road authority is preparing a program of civil works to help pedestrians cross national roads. Its engineers have been directed to inspect the national road network and to assess the pedestrian needs for civil works. They have hundreds of kilometers of road, and dozens of towns and villages, to inspect. The budget will be limited, so they must choose effective but low-cost treatments to assist the most deserving sites first.

1. Safety issues

329. During their national inspection tour, the engineers find this zebra crossing in a small village along a CAREC highway. The engineers notice that older students act as “supervisors,” helping younger children across the road, and that this supervisor stands close to the road pavement (for better visibility). They also note the unpaved shoulder has large puddles (which discourage use of the area), and an open drain that must be crossed to get to and from the zebra crossing. The line marking of the crossing is worn, and the regulatory pedestrian crossing signs are a long way off the road. Some approaching drivers may not be aware of this crossing.

2. Considerations

330. The crossing is in a village, the highway has just one lane per direction, and traffic volumes are low (less than 1,500 vehicles per day [vpd]).

Schoolchildren are the main users of the crossing. The supervisors appear to be useful and drivers obey them despite the poor condition of the crossing and its surroundings. The engineers discuss the issues and decide on a package of civil works to help the pedestrians and the supervisor. They understand the need to spread their limited budget for this national program as far as practical, and their priority is to improve the crossing itself. They discuss upgrading the streetlights but note that the crossing is used mostly during the daytime by schoolchildren. After a night inspection, they decide not to change the lighting.

3. The agreed decisions

331. The team of engineers place this site on the national works program with recommendations for

- curb extensions (15 m long by 3 m deep) constructed on both sides of the highway;
- a 3-m-wide bridge over the open drain;
- renewed zebra markings and 100 m of centerline;
- placing the renewed zebra crossing on a flat-topped road hump;
- new regulatory pedestrian crossing signs placed closer to the highway, on the curb extensions (for better conspicuity).

4. The result

332. The design drawings were available within 3 months. An estimate of costs was prepared, and the required budget approval was sought. The site did not receive funding in the first year of the national program as other sites on busier highways took



“Before.” The team identified this zebra crossing as a candidate site to be upgraded under the national pedestrian improvement program.

priority. But the national program of civil works has been well received by residents in many towns and villages across the country. The road authority will

continue the program for at least four more years and it is expected that this site will be improved in year 2 or year 3.

Figure 21: Case Study 5

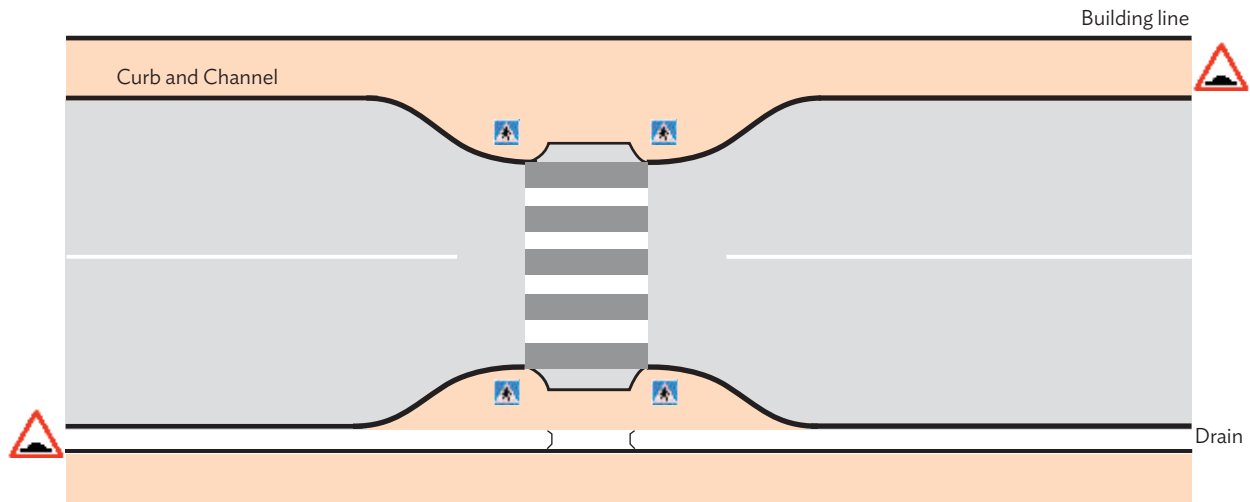

When this work is completed, pedestrians will have easier access to the crossing via the small bridge, and the crossing will be more conspicuous to approaching drivers. The curb extensions will help pedestrians (especially the schoolchildren) to see and be seen. A zebra crossing is a reasonable facility for this location (with just one lane in each direction, and within a village). The flat-topped road hump will manage traffic speeds at the most critical location, further adding to pedestrian safety. Humped crossings have been shown to reduce pedestrian casualty crashes by up to 73%.

Source: ADB road safety engineering consultant.

F. Case study 6

A national highway passing through a small village

333. A small village is the center for a large farming district. Farmers come together to hold a market three times each week during the growing season. The market stalls are spread along both sides of the national highway that passes through the village, and pedestrians tend to take over the highway at the busiest market times. In the past year, some motor vehicles, mainly trucks and buses, have passed through the market crowds at speeds considered to be too high. There are reports of several collisions, and numerous near misses, with local people attending the market.

334. Engineers from the road authority are directed to inspect the national highway and to assess the pedestrian needs in the village, especially during market times. They observe that the traffic volumes

are low (less than 1,000 vpd), with a mix of trucks, buses, minibuses, cars, and motorcycles. The market starts at 6 a.m. and finishes around midday. There are many pedestrians during these times, and they occupy a large part of the highway for much of this time.

1. Safety issues

335. There is no alternative route for the traffic to use (even just for market times), as the national highway is the only road through the village. It is unlikely that funds to construct a road bypassing the village, or to widen or upgrade the highway through the village, can be made available. It is also clear that the stallholders do not want to move their market away from the highway, as they rely heavily on passing traffic for their trade.

336. There are a few traffic signs along the road, well outside the village, but others are damaged or missing, and so drivers do not get a consistent message as they approach the village. This village is remote from other



“Before.” The traffic on the national highway presents a high risk to the pedestrians in the village, especially on market days.

settlements; driver fatigue on this highway is a definite safety concern, as truck and bus drivers travel long distances (more than 500 km) between two cities and this village is about halfway through their long journey.

2. Considerations

337. The engineers consider the three parts of the pedestrian strategy—segregation, separation, and integration—and conclude that integration is the only reasonable option here. They begin to explore options that will benefit pedestrian safety by managing vehicle speeds, especially at market times. To achieve this, police enforcement is desirable, but experience suggests this is not likely to be sustainable. The village is a long way from the regional headquarters of the police.

338. Traffic signs, including warning signs and speed restriction signs may have an impact, but the engineers are concerned that driver behavior (including driver fatigue) is unpredictable. The engineers discuss ways of highlighting these signs only at market times. They discuss flashing yellow signals above gateway signs that are switched on and off by a responsible villager. They consider placing part-time signs on the highway for market times only. But who will be responsible for controlling the signal, where will the part-time signs be stored when not needed, and how sustainable is such an option? They decide to stay with established signage practices, and they explore the use of road humps to control vehicle speeds.

339. A more permanent, self-enforcing form of speed management is needed. The engineers discuss the merits of installing flat-topped road humps in the village, at 70–80 m spacings. They know these will be the most effective and most sustainable device for managing speeds to around 35 km/h, but they are concerned that road humps have not been used on national highways before. They recognize the difficulty of choosing between comfort and travel times for highway traffic, while enhancing safety for the villagers at market times. They know that crossings

on road humps typically have up to 70% fewer serious or fatal pedestrian crashes. They also recognise that they need to be sure they offer a sustainable way to slow traffic in the village. And they are aware of the need for drivers to be able to see and safely negotiate humps, every day and every night, even when the market crowds have left.

3. The agreed decisions

340. The engineers decide to recommend a package of works that includes:

- large, duplicate (on both sides of the highway) warning signs for the village market 1 km, and again 500 m, from the village on both highway approaches;
- a pair of large “gateway” signs at each end of the village, with the words “Welcome to Dhari” plus a 30 km/h speed restriction sign and an additional plate saying, Pedestrians;
- 80 km/h speed restriction signs on the back of the gateway signs, facing the drivers leaving the village; and
- five flat-topped road humps at 80 m spacings to manage speeds in the village.

341. They explain this package of measures in their report to their manager and seek approval to proceed. The full report is approved, although the number of road humps is reduced from five to three, and the spacings are increased to 100 m.

4. The result

342. The signs and the flat-topped road humps were installed quickly at modest cost. These humps are the first to be installed in the province and the road authority is monitoring them closely. So far, they appear to have been accepted by all road users, including long-distance drivers. The locals are pleased that speeds have decreased noticeably, and the market is benefiting from this. Several other villages in the region have since requested similar traffic calming measures to be installed by the road authority.

Figure 22: Case Study 6

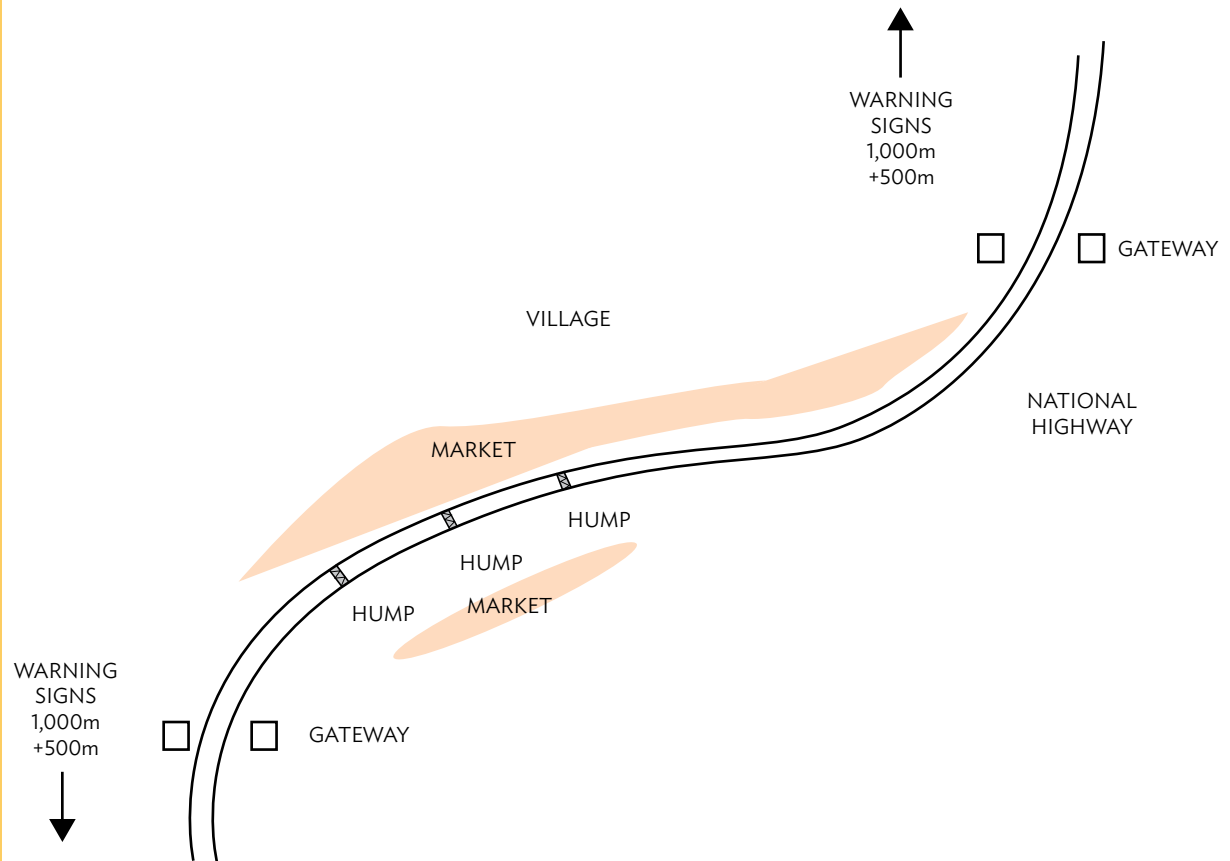

This initiative to calm the highway traffic through this village has been well received by the road users. It serves the market crowds, and it also slows the traffic at all other times, day and night. It will be critical to maintain the advance warning signs and the line markings in good order so that the humps always remain conspicuous.

m= meter.

Source: ADB road safety engineering consultant.

G. Case study 7

Fixed time pedestrian signals on a wide divided highway

343. A six-lane divided highway leads from the city to the international airport. It has lighting and footpaths along both sides, as well as five pedestrian signals and two pedestrian (zebra) crossings within a length of about 6 km. The abutting development is a commercial–residential–educational mix. The speed limit is 60 km/h, but speeds are much higher than this after dark.

344. The pedestrian signals are fixed-time signals; pedestrians can wait as much as one minute to get a Walk signal. The signals call up the Walk interval regardless of whether there is a pedestrian need. This means that some drivers face a red signal (especially late at night) when there are no pedestrians, and some of these drivers pass through without stopping.

1. Safety issues

345. The traffic police have reported that serious casualty crashes (death and serious injuries) involving pedestrians along this road have been rising. The crash data show that 11 pedestrians were killed on this road in the previous year. The data are sparse, but the police say that all the fatalities were intoxicated adult pedestrians who were struck late at night.

346. They point out to the road authority engineers that residents have been asking them to install more zebra crossings and to introduce a lower speed limit on the road. The police seek assistance from the road authority, and they travel together with the engineers for a nighttime inspection. On the night of the inspection, more than 2 km of the lights at the western end of the road, and about 10% of the remaining streetlights, are not working (for unknown reasons).



“Before.” The combination of a wide road, a potential for high traffic speeds, intoxicated pedestrians, fixed time pedestrian signals and unreliable lighting led to many nighttime pedestrian fatalities here.

347. The pedestrian crash data indicate a serious problem with intoxicated adult pedestrians involved in collisions at night. While everyone would like to see a change in human behavior so that alcohol-affected or drug-affected pedestrians remain at home, or at least away from busy roads, this is a social problem for others to address. The task of the engineers is to provide facilities that serve all their customers (including intoxicated pedestrians) safely and efficiently.

2. Considerations

348. The engineers note that five sets of pedestrian signals and two zebra crossings are already installed; they know that the wide median (10 m wide) is a help to pedestrians as it offers a large refuge for them. They decide there is no need for further spatial separation (such as curb extensions), as sight lines are already good.

349. The existing fixed-time pedestrian signals provide time-separation, but they operate suboptimally, creating longer delays than desirable for the pedestrians and for the drivers. The signals turn red to both directions of traffic at the same time, allowing pedestrians to cross the entire divided road in one movement. This creates unnecessary delays to drivers and appears to be leading to considerable driver disregard for the signals, especially late at night. The investigating engineers decide to add pedestrian push buttons to activate the pedestrian signals. This will be a small cost, but it could lead to much greater respect for the crossings, especially outside of peak times. They also decide to change the signal phasing so that only traffic in one direction is stopped at a time. The signals themselves are not as conspicuous as desirable, and the engineers recommend an additional signal head at each crossing, along with large black target boards. Critical for safety is the high risk involved with zebra crossings on three-lane roads. Zebra crossings should not be installed on any road with more than one lane in each direction. The investigation team decides to replace both zebra crossings with POSs.

350. Selecting a safe gap in three lanes of fast-moving traffic is a difficult task. This high-risk task is made much more difficult if the person is intoxicated. There is no certainty that intoxicated pedestrians are using the existing crossings. There is no guarantee they will use the improved crossings. However, if the signals can

be converted to POSs, with push button activation, at least they can be responsive to pedestrian demands. In time, driver and pedestrian compliance may improve.

351. Because the fatal collisions all occurred at night, it is decided to make pedestrians more conspicuous by improving the streetlights at or near each crossing. Speeding is also more of an issue at night, and to counter this, the engineers discuss the option of placing the crossings on flat-topped road humps. They support this option as a potentially effective measure based on international experience. Crossings that are on road humps typically have up to 70% fewer serious or fatal pedestrian crashes.

3. The agreed decisions

352. The engineers decide on a three-stage approach:

Stage One

- Add pedestrian push buttons to the five sets of signals so that they become POSs.
- Retime the signals so that only one direction of traffic stops at a time. This initiative will reduce driver delays and should further improve driver compliance with the signals.
- Add two floodlights at each crossing.
- Install several new lengths of pedestrian fencing to direct more pedestrians to the crossings; pave the waiting areas at each crossing.

Stage Two

- Replace the two zebra crossings with new POSs for consistency along the route.
- Replace all the warning signs with the correct warning signs (Signals Ahead).

Stage Three

- Construct road humps under each crossing and mark them accordingly

353. They submit their report to the head of their department. Because of the significance of the recommended changes, as well as the awareness that the road is highly dangerous for pedestrians, the head of the department convenes a meeting with police officials to discuss the most suitable way forward.

354. It is agreed that the push button activation and the phasing change to the signals (for stopping only one direction of traffic at a time) should be installed as soon as possible. It is further agreed to convert the two zebra crossings to POSs as soon as funding is available. Floodlighting of each crossing is also readily agreed, along with the improvements to the signs. However, the Stage Three road humps are not approved for immediate installation but will be considered by the road authority once the outcomes of the first stage works are known.

4. The result

355. The pedestrian push buttons were quickly added to the signals, and the new signal phasing was introduced. Within 3 months the police were reporting a decrease in the number of pedestrian collisions along this road. This reduction was pleasing and reassuring to the officials involved but it needs to be examined over a longer period of time. A small task force (engineers and police) are monitoring the crash data along this road, and they prepare six monthly reports for their organizations.

356. The two new POSs (to replace the zebra crossings) and the new floodlighting are programmed to be installed within the year.



“After.” Intoxication is a major health problem. The Safe System demands a road network that understands that humans are not perfect, they do make mistakes, but they should not pay a heavy price (death or serious injury) for those mistakes. The new push buttons along this road have been welcomed by the pedestrians; stopping just one direction of traffic at a time has been welcomed by the drivers. Recent maintenance of the streetlights means they now work well, and the road is better illuminated at night. Overall, police are pleased with the reduction in serious and fatal crashes along this road.

IX. Next Steps

357. Everyone is a pedestrian, and every journey begins and ends with a single step. To reduce pedestrian trauma in CAREC countries, stakeholders must work together on a coordinated approach to this problem under the direction of an agreed national road safety strategy and a national road safety action plan.

358. An agreed and funded national road safety action plan is essential for long-term assistance to pedestrians. This manual offers practical advice to those people who are responsible for implementing an action plan and for providing pedestrian facilities across the CAREC road network. It covers many topics within this important field, but some of the messages of this manual are more important than others. In short, there are several key messages to take away from this manual, as discussed below.

Build trust with pedestrians; provide them consistently with facilities that help them, and do not delay them unnecessarily.

A. Government policies are paramount

359. Governments are encouraged to put resources toward a targeted approach to improving safety and amenity for the group of road users that is by far the largest in each country.

- Commit to, and implement, a 10-year national road safety strategy that is based on Safe System principles.
- Develop, fund, and implement a national road safety action plan that includes immediate action to assist pedestrians.
- Do not forget the pedestrians. They are the building blocks of national transport systems.

B. Road authorities lead national actions

360. Road authorities are urged to make pedestrian safety a top priority. There are six important things to do, regardless of the budget available:

- Commit to a 5-year road safety action plan that includes action to assist pedestrians. Do not forget the pedestrians.
- Commit to a countrywide or citywide program of pedestrian improvements. This may be a low-cost program (increasing clearance times, replacing missing warning signs, and upgrading streetlights), a medium-cost program (installing curb extensions, curb ramps, and pedestrian refuges) or a higher-cost program (installing PUFFIN crossings, and grade separation). Ideally, it will be all of these.
- Review all national standards dealing with pedestrian facilities and ensure that these are updated to match the best international standards. Learn from others.
- Be guided by Safe System principles, and in particular manage speeds. If struck at 30 km/h, 90% of pedestrians survive, but if struck at 50 km/h, less than 45% will survive. Calm traffic on national roads in towns and villages, and on local streets.
- Work closely with the traffic police to improve crash data recording and analysis. Monitor the performance and the crash history of pedestrian facilities. Watch for problem signs and act early to minimize safety issues.
- Ensure that the national road rules are clear about all pedestrian issues.

C. Engineers manage many good programs for pedestrian safety

361. Engineers, designers, and technicians are the decision makers who influence the facilities that are provided for pedestrians. Their work is vital, and they should strive to:

- Build trust with pedestrians; provide facilities that help them, but not delay them unnecessarily.

- Design for all, including high-risk pedestrians (children, seniors, the disabled, and the intoxicated).
- Inspect the network and manage annual works programs of footpaths, pedestrian refuges, curb extensions, curb ramps, streetlights, bridges over drains, and pedestrian fencing.
- Traffic-calm local streets in cities and towns, and on main roads through villages.
- Maintain existing facilities. Inspect existing pedestrian facilities to improve each one within a budget. For example, increasing the clearance time at pedestrian signals is vital for safety, and costs next to nothing.
- Remember that not all pedestrian problem sites need a formal crossing. Sometimes streetlights, small-scale civil works, and warning signs give excellent results.

D. Engineers can do many good individual things...

362. Some of the best things that engineers can do to assist pedestrian safety include the following:

- Place crossings on road humps.
- Add pedestrian push buttons, and audio-tactile devices to all pedestrian signals.
- Increase pedestrian clearance times at signals.
- Introduce PUFFIN crossings. They are the best time separation facility available.
- Maintain existing facilities. Manage parking and keep vegetation clear so that sight lines and footpaths are kept open.

E. ...But engineers need to be cautious with other things

363. Some things that require careful consideration by engineers include the following:

- Do *not* install passive crossing (zebra crossings) on roads with more than one lane in each direction unless low speeds (around 30 km/h) can be guaranteed. These crossings rely on drivers seeing the pedestrians. A stopped vehicle in one traffic lane can obscure a pedestrian on a crossing from the driver of an overtaking vehicle.
- Do *not* install passive crossings (zebra crossings) on high-speed roads (typically 60 km/h or more).
- Do *not* construct pedestrian footbridges or subways without first consulting with the future users. These may be the right facility in some locations, but they can be underused in others. Much more can usually be done for the pedestrians at less cost.

F. Walking is good for everyone

364. The following fundamentals should be remembered:

- Walking is good for individuals, for communities, and for countries.
- Pedestrians are the largest group of road users, and the most vulnerable. They need good facilities.
- Consistency across the network builds trust. When pedestrians are given the level of service they expect, they learn to trust those responsible. With trust comes compliance, and eventually safer roads for all.
- Do *not* forget the pedestrian.

Pedestrians should be given the facilities they need, where and when they need them. Whether crossing roads, or walking along roads, pedestrians are vulnerable; they need assistance. Putting the Safe System to work will help pedestrians and all road users. CAREC roads will be better and much safer for this.



Pedestrians are vulnerable. They are the largest group of all road users and they benefit greatly when engineers provide them with safe, practical facilities.

Appendix 1: Advanced Signal Options to Assist Pedestrians

1. Traffic signals are an essential part of a traffic management network and there are numerous texts and manuals about how best to use these. The following table summarizes some of the most popular

modal options for pedestrians, involving complex signal operations within advanced signal systems. These require inputs from specialist signal engineers who can provide advice on appropriate phasing

Option	Description
Exclusive signal phase for pedestrians	Prevents traffic on all approaches from entering the intersection and allows pedestrians exclusive crossing access. The pedestrian phase is not timed for diagonal movement. Suitable locations include those near high-pedestrian-use sites like transport interchanges and shopping centers.
Exclusive “scramble crossing” or “Barnes dance” phase	Allows all pedestrian movements, including diagonal movements, to operate simultaneously within the marked limits of the crossing while eliminating vehicle conflicts. The pedestrian phase is timed for the diagonal (longest) movement and it operates as an exclusive signal phase. Scramble phasing eliminates conflict between pedestrians and turning vehicles, consolidating all pedestrian movements at an intersection into one phase. However, this depends on good pedestrian compliance with the Don’t Walk signal during the vehicle phases. They are generally good for sites with high pedestrian and turning vehicle volumes, but they do increase overall delays.
Double cycling within a coordinated network	In areas where traffic signals are coordinated and with high pedestrian volumes, a minor intersection or midblock crossing may use a cycle time that is half the length of adjacent signals. This reduces pedestrian waiting times, while still allowing for traffic signal coordination.
Dwell on red for all users, or dwell on walk (green) for pedestrians	The traffic signals display red for all movements until a pedestrian (or vehicle) is detected. Alternatively, a traffic signal dwells on the pedestrian Walk interval until a vehicle is detected. These may be appropriate where pedestrian volumes are high and vehicle volumes are low (e.g., late at night near areas of alcohol consumption).
Extended clearance intervals	Lengthens the clearance intervals for slower pedestrians (e.g., midblock crossings outside schools). This can also use active detection such as that used with PUFFIN crossings.
Extended walk/stretch walk/rest in walk	The pedestrian walk interval is kept as long as possible with the parallel vehicle green signals. In adaptive signal systems, the vehicle green phase varies. This allows the parallel pedestrian phase to be varied.
Reduced cycle lengths	Reduce cycle lengths to reduce waiting time for pedestrians in areas of high pedestrian activity (e.g., city centers).
Fixed demand or auto introduction	Controller is set to register demand for a pedestrian movement on every cycle. Should only be considered where/when pedestrian volumes are high (e.g., city centers) to avoid pedestrian phases without pedestrian demand.
Isolated traffic controls at areas with high pedestrian demand	The traffic control is isolated instead of being coordinated with others. This may reduce pedestrian wait time by decreasing the signal cycle time or skipping phases. Generally applied to coordinated signals with very long cycle times, where pedestrian level of service is determined to be of higher priority. May only be applicable to certain times of day.
Pedestrian countdown timers	Countdown timers show the time remaining until the end of the pedestrian clearance interval, to improve pedestrian behavior and potentially reduce pedestrian delay.
Reintroduction of pedestrian walk	Pedestrian walk interval is reintroduced after the pedestrian phase has timed out on the main road phase, but there is no traffic on the conflicting phase(s).

sequence options, associated model inputs, and other critical elements. The options outlined below are put forward for engineers and planners to think about for their traffic signals if and when the network has the capacity for these advanced options. Note that these options are typically applicable only in low-speed central urban areas with many pedestrians. They can do much to assist pedestrians in these situations, noting that vehicle delays may increase. With the right planning and coordination, urban environments can be enhanced greatly with the use of such options; they demonstrate a high level of attention to the needs of the pedestrians.

2. Protection for pedestrians must always be considered at signalized intersections. This usually involves trade-offs between intersection capacity and pedestrian safety, and the ability to make these trade-offs depends on the technical capacity of the signal control system. One of the greatest risks to pedestrians at signalized intersections is left-turning (right-turning in Pakistan) drivers. These drivers, focused on selecting a gap in oncoming traffic, forget or ignore the pedestrians who may be crossing the road they are turning into.

3. Where this is a problem, the common way of assisting the pedestrians is to install full turn control for the traffic. Full protection for pedestrians should be provided whenever pedestrians are placed at an unnecessarily high risk, such as when

- sighting to the crossing is restricted;
- the speed of the turning traffic is high; or
- there are two lanes (or more) of vehicles turning left (or right) through the pedestrian movement, and those turning vehicles are opposed by oncoming traffic.

4. On the other hand, pedestrian protection (full or partial signal control) is usually unnecessary when all the following conditions are met:

- the crossing is clearly visible to the turning drivers;
- the volume of turning vehicles is low, and it includes few large vehicles;
- there is only one lane of vehicles turning left (or right); and
- the speed of the turning traffic is low.

5. In a modern, vehicle-actuated signal system, linked with many other intersection signals under a regional coordination network, the degree of protection provided for the pedestrians depends on the circumstances and may be

- full protection by a red arrow (or red circle) for the entire walk and clearance intervals;
- timed protection by a red arrow (or red circle) for part of the walk interval; or
- various combinations, including protection by a red arrow for the whole of the walk interval or part of the clearance interval, or by a red arrow (or red circle) for the whole of the walk interval.

6. The length of the timed protection depends on the type of pedestrians using the crossing, the flow of pedestrians, and the flow of conflicting vehicles. The length of timed protection can be varied by the time of the day, such as at school entry and exit times.

7. Timed protection should be provided when

- there are two or more lanes of vehicles turning left (or right in Pakistan) through the pedestrian traffic, where those turning vehicles are unopposed; or
- where left or right arrow displays are present and there is an associated conflicting movement.

8. Timed protection should be considered when

- there is a high volume of turning traffic and low pedestrian flow;
- the flow of pedestrians is high;
- there is a high proportion of children, the elderly, or people with disabilities; or
- the length of the crossing results in a long clearance time.

Appendix 2: Crash Reduction Factors

	Pedestrian Treatments	CRF for All Casualty Crashes (%)	CRF for Specific Casualty Crash Type	Treatment Life (years)
1	Pedestrian refuges		50% Pedestrian crashes 67% Fatal pedestrian crashes	25
2	Painted (flush) median: urban		50% Pedestrian crashes	5
3	Pedestrian-operated signals		39% Pedestrian crashes	15
4	Exclusive pedestrian signal phase at intersection		50% Pedestrian crashes	15
5	Improved signal timing		35% Pedestrian crashes	15
6	Upgrade marked crossing (nonsignalized) to signalized crossing		27% Pedestrian crashes	15
7	Flashing sign Give Way to Pedestrians plus pedestrian phase priority at signalized intersection		35% Pedestrian crashes	15
8	Pedestrian overpass		85% Pedestrian crashes	25
9	Pedestrian fencing and barriers		23% Pedestrian crashes	20
10	Improved lighting at pedestrian crossings		60% Pedestrian crashes (nighttime only) 30% Pedestrian crashes	20
11	Dwell on red signal phase	47	50% Pedestrian crashes during the operating time	15
12	On road bicycle paths: green marking	25		5
13	40 km/h speed reduction: strip shopping center with electronic and static signs	8	15% Pedestrian crashes	15
14	50 km/h default speed limit		23% Pedestrian crashes 41% Pedestrian FSI crashes	20
15	50 km/h default limit reduced from 70 km/h limit		61% Pedestrian crashes	20
16	Boy-and-girl painted images on school crossing crosswalk		5% Pedestrian crashes Derived from 2 km/h speed reduction using Nilsson model	
17	Tram signal Tram signal and lane priority	17	13% Pedestrian crashes 19% FSI crashes	15
18	Tram platform stops		81% Pedestrian crashes 86% Pedestrian FSI crashes	20
19	Raised crossing (on a hump)	63	73% Pedestrian crashes	20
20	Ban parking		30% Pedestrian crashes	20
21	Barnes dance crossing		9% Pedestrian crashes	20
22	Footpath and shoulder provision		88% Pedestrian crashes (walking along)	25
23	High-visibility crosswalk (zebra crossings with additional markings, lighting, colors)		44% Pedestrian crashes	20

continued on next page

Table continued

	Pedestrian Treatments	CRF for All Casualty Crashes (%)	CRF for Specific Casualty Crash Type	Treatment Life (years)
24	Traffic signals (new control at intersections)		30% Pedestrian crashes	15
25	PUFFIN crossings		26% Pedestrian crashes	20
26	Raised intersection platforms	20	8% Pedestrian crashes	20
27	Traffic calming: all environments	20	50% FSI pedestrian crashes (with 30 km/h speed limit) 65% pedestrian crashes (with 30 km/h speed limit)	20
28	Traffic calming and 30 km/h speed limit		65% Pedestrian crashes 50% Pedestrian FSI crashes	20
29	Speed limit reduction: gateway for rural village (signs and pinch point) Reduce from 100 km/h to 80 km/h	35	41%FSI crashes	15
30	Static signs reduce from 70 to 50 km/h		61% pedestrian crashes	
31	Dragon's-teeth pavement marking on approach to intersections or rural curves (in 80 km/h zones)		21% of speed related crashes	5
32	Improved lighting at pedestrian crossings		60% Pedestrian crashes (night only) 30% Pedestrian crashes	20

CRF = crash reduction factor, FSI = fatal and serious injury, km/h = kilometer per hour, PUFFIN = pedestrian user-friendly intelligent (crossing).

Source: From the VicRoads Road Safety Program, 2017, and modified by the ADB road safety engineering consultant. It should be noted that these CRF's come from a non-CAREC country; they may not apply equally in the CAREC region. In time it is expected that CRF's will be developed from before/after casualty crash data from CAREC countries.

Appendix 3: The Stockholm Declaration

Third Global Ministerial Conference on Road Safety: Achieving Global Goals 2030 Stockholm, 19–20 February 2020

Reiterating our strong commitment to achieving global goals by 2030 and emphasizing our shared responsibility, we hereby resolve to;

1. Reaffirm our commitment to the full implementation of the 2030 Agenda, recognizing the synergies between the Sustainable Development Goals (SDGs) policy areas, as well as the need to work in an integrated manner for mutual benefits;
2. Address the connections between road safety, mental and physical health, development, education, equity, gender equality, sustainable cities, environment and climate change, as well as the social determinants of safety and the interdependence between the different SDGs, recalling that the SDGs and targets are integrated and indivisible;
3. Call upon Member States to contribute to reducing road traffic deaths by at least 50% from 2020 to 2030 in line with the United Nations High-Level Political Forum on Sustainable Development's pledge to continue action on the road safety related SDG targets, including 3.6 after 2020, and to set targets to reduce fatalities and serious injuries, in line with this commitment, for all groups of road users and especially vulnerable road users such as pedestrians, cyclists and motorcyclists and users of public transport;
4. Call upon Member States and the international community to address the unacceptable burden of road traffic injury on children and young people as a priority, increasing political commitment, by ensuring that the Global Strategy for Women's, Children's and Adolescents' Health delivers necessary action on road safety;
5. Ensure political commitment and responsibility at the highest level and establish regional, national and subnational strategies and action plans for road safety and contributions from different governmental agencies as well as multi-sectoral partnerships to deliver the scale of efforts required at regional, national and sub-national levels to achieve SDG targets, and that these strategies and efforts are transparent and public;
6. Encourage Member States that have not yet done so to consider becoming contracting parties to the United Nations legal instruments on road safety as well as applying, implementing and promoting their provisions or safety regulations, and ensure that legislation and standards for road design and construction, vehicles, and road use are consistent with safe system principles and are enforced;
7. Include road safety and a safe system approach as an integral element of land use, street design, transport system planning and governance, especially for vulnerable road users and in urban areas, by strengthening institutional capacity with regard to road safety laws and law enforcement, vehicle safety, infrastructure improvements, public transport, post-crash care, and data;
8. Speed up the shift toward safer, cleaner, more energy efficient and affordable modes of transport and promote higher levels of physical activity such as walking and cycling as well as integrating these modes with the use of public transport to achieve sustainability;
9. Encourage and incentivize the development, application and deployment of existing and future technologies and other innovations to improve accessibility and all aspects of road safety from crash prevention to emergency response and trauma care, with special attention given to the safety needs of those road users who are the most vulnerable including pedestrians, cyclists, motorcyclists and users of public transport;
10. Ensure timely access to high quality emergency and long-term health care services for the injured and recognize that an effective postcrash response includes also mental, social and legal support for victims, survivors and families;

11. Focus on speed management, including the strengthening of law enforcement to prevent speeding and mandate a maximum road travel speed of 30 km/h in areas where vulnerable road users and vehicles mix in a frequent and planned manner, except where strong evidence exists that higher speeds are safe, noting that efforts to reduce speed in general will have a beneficial impact on air quality and climate change as well as being vital to reduce road traffic deaths and injuries;
 12. Ensure that all vehicles produced and sold for every market by 2030 are equipped with appropriate levels of safety performance, and that incentives for use of vehicles with enhanced safety performance are provided where possible;
 13. Ensure that an integrated road safety approach and minimum safety performance standards for all road users are a key requirement in road infrastructure improvements and investments;
 14. Call upon businesses and industries of all sizes and sectors to contribute to the attainment of the road safety related SDGs by applying safe system principles to their entire value chain including internal practices throughout their procurement, production and distribution process, and to include reporting of safety performance in their sustainability reports;
 15. Call upon public organizations at all levels to procure safe and sustainable transport services and vehicles and encourage the private sector to follow this example, including the purchase of safe and sustainable vehicle fleets;
 16. Encourage increased investment in road safety, recognizing the high rates of return of road injury prevention projects and programs and the necessity of scaling up activities to meet the road safety related SDGs;
 17. Emphasize the importance of monitoring and reporting progress toward the achievement of our common goals and, as appropriate, the Voluntary Global Road Safety Performance Targets agreed by Member States, and call upon the World Health Organization to continue to collect, publish and disseminate data through the series of Global Status Reports on Road Safety, leveraging as appropriate existing efforts including those of regional road safety observatories to harmonize and make road safety data available and comparable;
 18. Call upon the World Health Organization to prepare an inventory of proven strategies and initiatives from a wide variety of member countries that have successfully reduced fatalities in member countries. A report should be readied for publication in 2024. We call for a first High-Level Meeting of the United Nations General Assembly on Road Safety at the level of Heads of State and government to mobilize adequate national leadership and advance international and multisectoral collaboration in all the areas covered by this Declaration to deliver a 50% reduction in deaths and injuries over the next decade on our way to Vision Zero by 2050; and
- We invite the United Nations General Assembly to endorse the content of this declaration.

Glossary of Terms



Active crossings: Those pedestrian facilities that give right-of-way to pedestrians only when activated. A red signal is usually activated at these facilities to direct drivers to stop.

Advance warning sign: A sign that is placed in advance of a hazard to provide advance warning to approaching traffic.

CAREC: Central Asia Regional Economic Cooperation (Program)

CAREC highway: one of the designated national/international highways under the CAREC program.

Client: The road authority that is responsible for the road/highway.

Consultant: The Client's representative for the project.

Contractor: The company contracted to undertake the work for the Client.

Crash: A rare random multi-factorial event in which one or more road users fails to cope with their environment.

Crash reduction factor: the percentage reduction in casualty crashes that can be expected when a given safety treatment is installed. They are based on previous before and after crash studies of many sites.

Curb extension: Curb extensions are changes in the curb line that extend the curb into the road, and thereby reduce the road's effective width. In this way, they reduce pedestrian exposure to traffic, and improve pedestrian safety. They assist pedestrians to see and be seen before stepping onto the road.

Curb ramp: Curb ramps provide smooth access between the footpath and the road. They are for all pedestrians to use, but they are particularly useful places for pedestrians with mobility restrictions, in wheelchairs, or those using strollers, walkers, or

handcarts. Pedestrians can use the ramp to move from the road to the footpath, or vice versa, without having to step on and off high curbstones.

Delineation: A general term for the signs and devices that are used to provide clear definition of the designated traffic path.

Footbridge: A structure which provides for pedestrians to cross above a road. Another term for this device is a pedestrian overpass. It is a form of spatial separation.

Fragible: The ability of a device, including structure supports, posts and poles, to breakaway or to be deformed upon impact by an errant vehicle without causing significant risk of serious injury to vehicle occupants.

Gateway: The generic term used for an entranceway (made of signs, pavement markings and gantries) on the approach to a town or village that welcomes drivers and informs them they are entering a different driving environment.

High-speed road: A road where vehicle speeds are typically greater than 60 kilometers per hour (km/h).

Integration: The aspect of the pedestrian safety strategy in which pedestrians and motor vehicles share the road space, within agreed road rules.

Intoxicated pedestrians: Pedestrians who have changes in their perception, mood, thinking processes and motor skills as a result of the effect of a drug(s) on their central nervous system. It is commonly associated with alcohol, but it can also be connected to other drugs.

Left Turn On Red (LTOR): A road rule used in some countries where vehicles drive on the left side of the road, that allows a driver to turn left against a red traffic signal. It is intended to reduce delays and traffic congestion.

Low speed road: A road where vehicle speeds are typically 60km/h or less.

Multilane: Two or more traffic lanes in one direction.

Overpass: A structure which provides for pedestrians to cross above a road. It is a form of spatial separation. Another term for this device is a pedestrian footbridge.

Passive crossing: Those pedestrian facilities that require drivers to see the pedestrian on the crossing in order to give right-of-way to that pedestrian. The Pedestrian (Zebra) Crossing is a common example of a passive crossing.

Pedestrian: Any person on foot, including those who are in prams, pushers, wheelchairs, on skateboards and walking with a bicycle.

Pedestrian crossing: Commonly called a Zebra Crossing, this passive crossing has painted stripes on the road with regulatory signs nearby facing the drivers.

Pedestrian operated signal (POS): Traffic signals which include push buttons for pedestrians to use to record their intention to cross. POSs can be at intersections or at midblock locations. When the signals turn red to drivers, these crossings stop the traffic and create gaps which give pedestrians time separation.

Pedestrian underpass: A grade separated facility which allows pedestrians to walk beneath a road. Another term for this facility is a pedestrian subway. An underpass is one form of spatial separation.

PELICAN crossing: A version of a Pedestrian Operated Signal which displays a pre-set flashing yellow signal during the phase when it opens up to the motor vehicles. The name PELICAN derives from Pedestrian Light Control crossing.

Posted speed limit: The signed maximum legal speed limit for a road.

PUFFIN crossing: a version of a Pedestrian Operated Signal which has a small overhead detector to determine if a slow-moving pedestrian using the crossing requires additional clearance time. The name PUFFIN derives from Pedestrian User-Friendly Intelligent crossing.

Refuge: A physical island in the center of a road that provides space for pedestrians to stand on while staging their road crossing. A refuge is a form of spatial separation.

Right Turn On Red (RTOR): A road rule used in some countries where vehicles drive on the right side of the road, that allows a driver to turn right against a red traffic signal. It is intended to reduce delays and traffic congestion.

Roadside: The area between the boundary of the road reservation and the edge of the shoulder, or traffic lane in the absence of a shoulder. The median between carriageways of a divided road is also a part of the roadside.

Roadside hazard: Any feature located in the clear zone (along the roadside or within the median) that could cause significant injury to the occupants of an errant vehicle.

Road user: Any driver, rider, passenger, or pedestrian using the road.

Roadway: That portion of the road for the use of vehicles, including the shoulders and auxiliary lanes.

Roadwork: Any work on a road or a roadside that has potential to disturb traffic flow and/or safety.

Road worker: Any person engaged in work on a road or the roadside.

Safe System: The Safe System is an inclusive approach to road safety that involves a holistic view of the interactions among roads and roadsides, travel speeds, vehicles and road users. It recognizes that people make mistakes and may have road crashes, but the system should be forgiving, and those crashes should not result in death or serious injury.

Safety barrier: A physical barrier separating a hazard from the traveled way, designed to resist penetration by an out-of-control vehicle and (as far as practicable) to redirect the colliding vehicle back into the travelled path.

School crossing: a low-cost and part-time passive crossing that is used in Australia to give pedestrians priority over traffic when its flags are displayed. This type of crossing is usually operational at times schoolchildren are walking to or from school.

Segregation: The part of the pedestrian safety strategy in which pedestrians are segregated (kept apart) from motor vehicles. Pedestrian malls are one end of segregation, while expressways are the other.

Senior citizens: People who are 65 years of age, or older.

Separation: The part of the pedestrian safety strategy in which pedestrians are separated from motor vehicles by either time (temporal separation) or distance (spatial separation).

Shared zone: A length of road or street that is signed to create a zone in which pedestrians have priority over the motor vehicles, where motor vehicles are restricted in speed (usually 10 km/h or 20 km/h) and where vehicle parking is permitted only in marked bays.

Spatial separation: This is the element of the pedestrian safety strategy that separates pedestrians from motor vehicles in space (distance).

Subway: A grade separated facility that allows pedestrians to walk beneath a road. Another term for this facility is a pedestrian underpass. A subway is one form of spatial separation.

Tactile Ground Surface Indicators (TGSIs): These are a system of textured tiles placed on footpaths, steps, and other areas to guide and warn visually impaired pedestrians. There are two types of TGSIs (also called tactiles):

- Dimple tiles, with raised nodes, are warning tiles. They are used to warn the visually impaired of an immediate conflict point.
- Ribbed tiles, with raised ribs, are guidance tiles. They guide pedestrians to selected points and assist them at places where they may want to change direction.

Temporal separation: This is the element of the pedestrian safety strategy that separates pedestrians from motor vehicles in time.

Threshold treatments: A generic term for civil works around the perimeter of an area-wide traffic management scheme, usually in a busy urban area. It is the first device over or through which drivers pass as they enter the local area.

Traffic: All vehicles (including cars, trucks, buses, bicycles, motorcycles, and animal drawn vehicles), persons and animals traveling on the road.

Traffic calming: Involves the use of road humps, chicanes, roundabouts, pavement textures and markings, and other physical devices to slow traffic in local streets.

Traffic control devices: The signs, signals, crossings, barriers and other devices placed on or near the road to regulate, warn or guide road users.

Traffic lane: A portion of a road used for the movement of traffic (does not include shoulders).

Two-way roadway: A roadway with lanes allotted for use by traffic in opposing directions without physical separation between them.

Underpass: A grade separated facility that allows pedestrians to walk beneath a road. Another term for this facility is a pedestrian subway. An underpass is one form of spatial separation.

Vulnerable road user: a road-user group that is considered vulnerable, due to their relative frailty, in the event of a collision with a motor vehicle. The common groups of vulnerable road users on CAREC highways are pedestrians, bicyclists, motorcyclists, and animal drawn vehicles/carts.

Zebra crossing: The common term used for a Pedestrian Crossing. This is one type of passive crossing; it has painted stripes on the road with regulatory signs nearby facing the drivers.

References

- American Association of State Highway and Transportation Officials (AASHTO). 2004 (1st ed.). *AASHTO Guide for the Planning, Design, and Operation of Pedestrian Facilities*. Washington, DC.
- Asian Development Bank (ADB). 2003. *Vulnerable Road Users in the Asian and Pacific Region*. Manila.
- . 2017. *Safely Connected: A Regional Road Safety Strategy for CAREC Countries, 2017–2030*. Manila.
- . 2018a. *CAREC Road Safety Engineering Manual 1: Road Safety Audit*. Manila.
- . 2018b. *CAREC Road Safety Engineering Manual 2: Safer Road Works*. Manila.
- . 2018c. *CAREC Road Safety Engineering Manual 3: Roadside Hazard Management*. Manila.
- AUSTROADS, Australia. 2010. *Guide to Road Design Part 6: Roadside Design, Safety and Barriers*. AGRD06-10. Sydney.
- . 2013. 2nd ed. *Guide to Traffic Management Part 6: Intersections, Interchanges and Crossings*. AGTM06-13. Sydney.
- . 2016a. *Guide to Traffic Management Part 9: Traffic Operations*. AGTM09-16. Sydney.
- . 2016b. *Guide to Traffic Management Part 10: Traffic Control and Communication Devices*. AGTM10-16. Sydney.
- . 2017a. *Guide to Road Design Part 4: Intersections and Crossings—General*. AGRD04-17. Sydney.
- . 2017b. *Guide to Road Design Part 4A: Unsignalised and Signalised Intersections*. AGRD04A-17. Sydney.
- . 2017c. *Guide to Road Design Part 6A: Paths for Walking and Cycling*. AGRD06A-17. Sydney.
- . 2018. *Towards Safe System Infrastructure: A Compendium of Current Knowledge*. AP-R560-18. Sydney.
- . 2020a. *Guide to Traffic Management Part 9: Transport Control Systems— Strategies and Operations*. AGTM09-20. Sydney.
- . 2020b. *Road Cross-section Design for Road Stereotypes (including Network Safety Plans) and a Safe System*. AP-R618-20. Sydney.
- Department for Transport, United Kingdom. 2003. *Walking: The Way Ahead*. London.
- European Alliance for Safe and Sustainable Transport (EASST) and Public Association ‘Road Safety.’ 2018. *Pedestrian Safety in Bishkek’s Smart Cities Concept*. Kent, England, UK.
- Federal Highway Administration, U.S. Department of Transportation. 2013. *PEDSAFE: Pedestrian Safety Guide and Countermeasure Selection System*. Washington, DC.
- Florida Department of Transportation. 1999. *Florida Pedestrian Planning and Design Handbook*. Prepared by the University of North Carolina Highway Safety Research Center. Tallahassee.
- Global Road Safety Partnership. <https://www.grsproadsafety.org>.
- International Road Assessment Program (iRAP) 2017 www.irap.org.
- Land Transport New Zealand. 2007. *Pedestrian Planning and Design Guide*. Wellington.
- Ministry of Communications, Government of Pakistan. 2019. *Guidelines for Road Safety Engineering—Part 1*. Islamabad.

- Monash University Accident Research Centre. 2010. *Older Pedestrians: Meeting their Safety and Mobility Needs*. Paper prepared by Jennifer Oxley, Bruce Corben, Brian Fildes, and Judith Charlton. Melbourne.
- Ogden, Kenneth Wade. 1996. *Safer Roads: A Guide to Road Safety Engineering*. Vermont, United States: Avebury Technical.
- Raffo Gonzalez, Giannina Gisell, Sara Sultan, and Raymond Franklin Soames Job. 2020. *Global Road Safety Facility: Leveraging Global Road Safety Successes (Vol. 2)*. Washington, DC: Global Road Safety Facility, World Bank Group.
- Roads Corporation of Victoria, Australia (VicRoads). 2020. *Pedestrian Fencing. Road Design Note. RDN 06-14*. Melbourne.
- SWOV Institute for Road Safety Research. 2017. *Sustainable Safety, 3rd Edition: The Advanced Vision for 2018–2030*. The Hague, Netherlands.
- Transport Accident Commission (TAC). Speed statistics. <http://www.tac.vic.gov.au/road-safety/statistics/summaries/speed-statistics>.
- United Nations Road Safety Collaboration Group (UNRSC). 2020. *The Ten Step Plan for Safer Road Infrastructure*. Geneva.
- United States Department of Transportation National Highway Traffic Safety Administration (1981) *The Effect of Right-Turn-On-Red on Pedestrian and Bicyclist Accidents*. Washington
- University of North Carolina (UNC) Highway Safety Research Center. 2018. *Safe Systems Synthesis: An International Scan for Domestic Application (Final Report)*
- Wikipedia 2020. *Turn on red*
- World Bank. 2019. *Guide for Road Safety Opportunities and Challenges: Low- and Middle-Income Countries Country Profiles*. Washington, DC.
- World Health Organization (WHO). 2013. *Pedestrian Safety: A Road Safety Manual for Decision-Makers and Practitioners*. Geneva.
- . 2018. *Global Status Report on Road Safety 2018*. Geneva.
- World Resources Institute (WRI). 2018. *Sustainable and Safe: A Vision and Guidance for Zero Road Deaths* wri.org
- World Road Association (PIARC, the Permanent International Association of Road Congresses). 2017. *Vulnerable Road Users: Diagnosis of Design and Operational Safety Problems and Potential Countermeasures*. Paris.
- . 2019. *Road Safety Manual - a manual for practitioners and decision-makers on implementing safe system infrastructure. Edition 3*. Paris
- . 2020. *Vulnerable Road Users: Diagnosis of Design and Operational Safety Problems and Potential Countermeasures—Reference*. Paris.
- Zegeer, Charles V. 1998. *Design and Safety of Pedestrian Facilities: A Recommended Practice of the Institute of Transportation Engineers*. Washington, DC: Institute of Transportation Engineers.

CAREC Road Safety Engineering Manual 4

Pedestrian Safety

This manual is a practical point of reference for the provision of safer pedestrian facilities in Central Asia Regional Economic Cooperation (CAREC) countries. It focuses on the physical road infrastructure that can help pedestrians safely cross, and walk along, roads. It also outlines proven facilities that have been shown to assist pedestrians including those in the high-risk groups. Aimed at engineers, project managers, planners, traffic police, and other decision-makers, the manual shows how wise investment in pedestrian facilities can save lives, prevent injuries, and return major economic benefits to CAREC countries.

About the Central Asia Regional Economic Cooperation Program

The Central Asia Regional Economic Cooperation (CAREC) Program is a partnership of 11 member countries and development partners working together to promote development through cooperation, leading to accelerated economic growth and poverty reduction. It is guided by the overarching vision of “Good Neighbors, Good Partners, and Good Prospects.” CAREC countries include Afghanistan, Azerbaijan, the People’s Republic of China, Georgia, Kazakhstan, the Kyrgyz Republic, Mongolia, Pakistan, Tajikistan, Turkmenistan, and Uzbekistan. ADB serves as the CAREC Secretariat.

About the Asian Development Bank

ADB is committed to achieving a prosperous, inclusive, resilient, and sustainable Asia and the Pacific, while sustaining its efforts to eradicate extreme poverty. Established in 1966, it is owned by 68 members —49 from the region. Its main instruments for helping its developing member countries are policy dialogue, loans, equity investments, guarantees, grants, and technical assistance.



CAREC SECRETARIAT

www.carecprogram.org

ASIAN DEVELOPMENT BANK

6 ADB Avenue, Mandaluyong City
1550 Metro Manila, Philippines
www.adb.org